

E3631A

Triple Output DC Power Supply

Instructions for the use of the E3631A Triple Output DC Power Supply

This pamphlet is intended to give you (the student) an overview on the use of the E3631A Triple Output DC Power Supply. This pamphlet will instruct you on how to set and adjust the 3 available output voltages.

**Please visit the Agilent website
<http://www.home.agilent.com/agilent/home>
to view the complete user manual for more
information.**

Front-Panel Controls

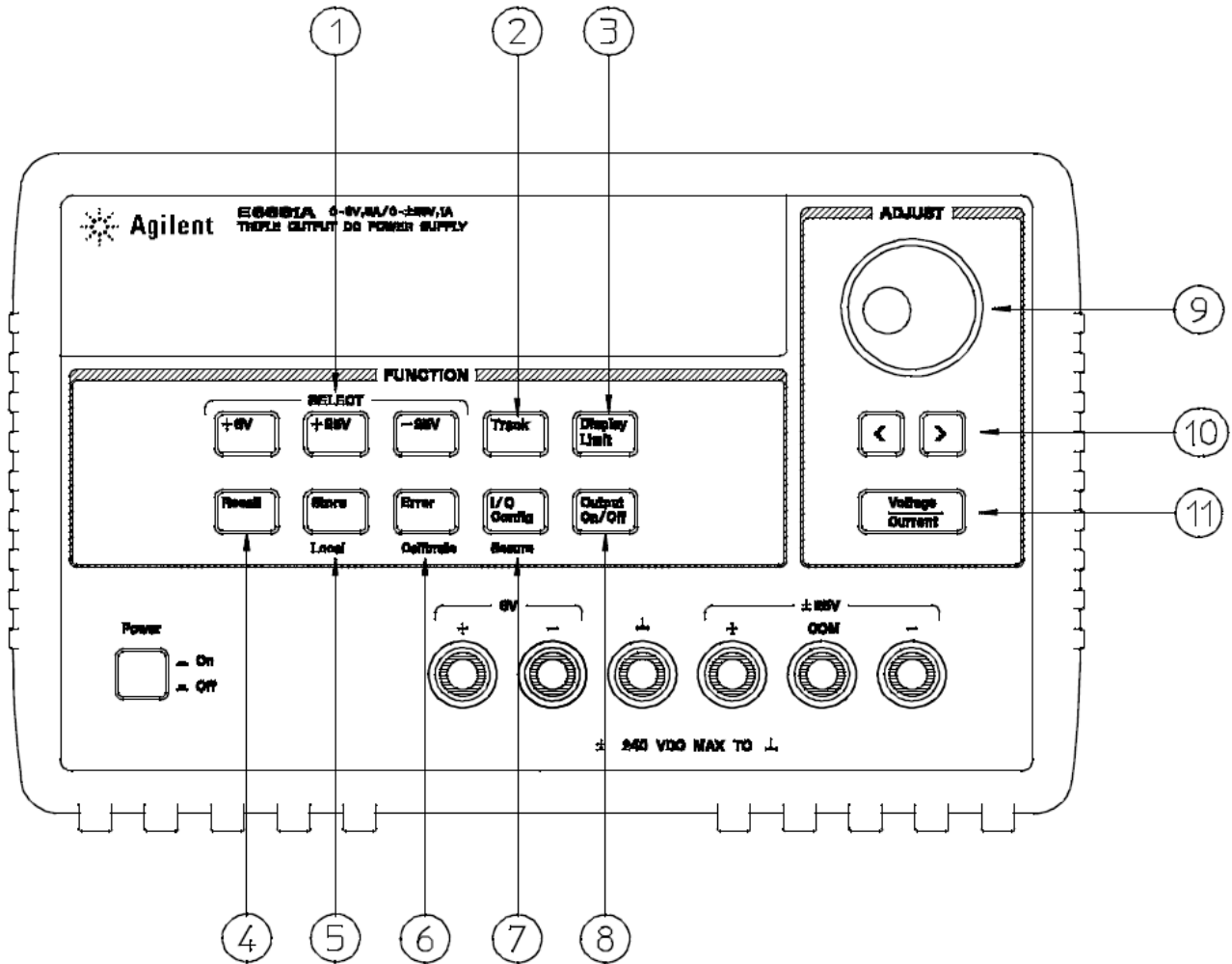



1. Meter and adjust selection keys
2. Tracking enable/disable key
3. Display limit key
4. Recall operating state key
5. Store operating state/Local key
6. Error/Calibrate key
7. I/O Configuration / Secure key
8. Output On/Off key
9. Control ↻ knob
10. Resolution selection keys
11. Voltage/current adjust selection key

1. **Meter and adjust selection keys** Select the output voltage and current of any one supply (+6V, +25V, or -25V output) to be monitored on the display and allow knob adjustment of that supply.
2. **Tracking enable / disable key** Enables / disables the track mode of $\pm 25V$ supplies.
3. **Display limit key** Shows the voltage and current limit values on the display and allows knob adjustment for setting limit values.
4. **Recall operating state key** Recalls a previously stored operating state from location "1", "2", or "3".
5. **Store operating state / Local key** Stores an operating state in location "1", "2", or "3" / or returns the power supply to local mode from remote interface mode.
6. **Error / Calibrate key** Displays error codes generated during operations, self-test and calibration / or enables calibration mode (the power supply must be *unsecured* before performing calibration).
7. **I/O Configuration / Secure key** Configures the power supply for remote interfaces / or secure and unsecure the power supply for calibration.
8. **Output On/Off key** Enables or disables all three power supply outputs. This key toggles between two states.
9. **Control ↻ knob** Increases or decreases the value of the blinking digit by turning clockwise or counter clockwise.
10. **Resolution selection keys** Move the flashing digit to the right or left.
11. **Voltage/current adjust selection key** Selects the knob function to voltage control or current control.

Front-Panel Voltage & Current Limit Settings

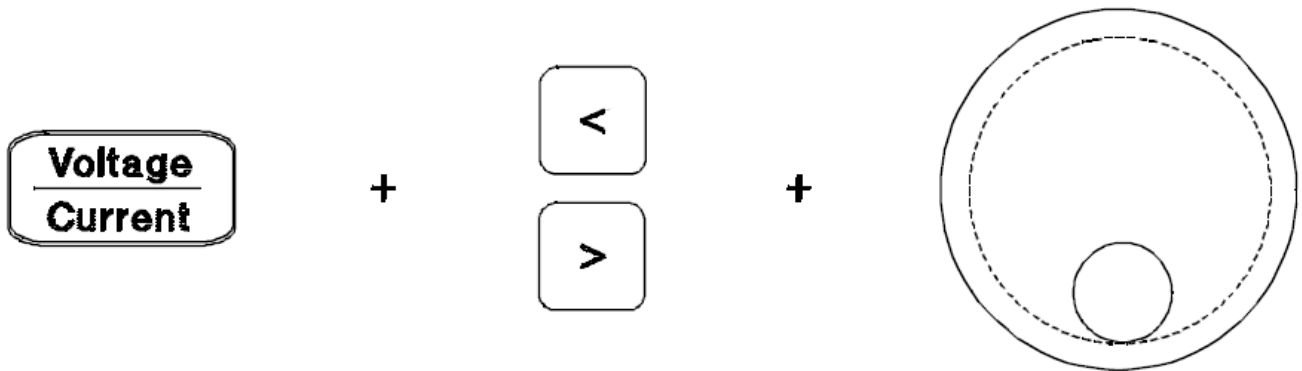
The voltage and current limit values may be set from the front panel using the following method.



1. Press the **[Display Limit]** key after turning on the power supply.
2. Set the control  knob to the voltage control mode or current control mode using the voltage/current adjust selection key.
3. Move the blinking digit to the appropriate position using the resolution selection keys.
4. Change the blinking digit to the desired value using the control  knob.
5. Press the **[Output On/Off]** key to enable the output. After about 5 seconds, the display will go to the output monitor mode automatically to display the voltage and current at the output.

Display Annunciators

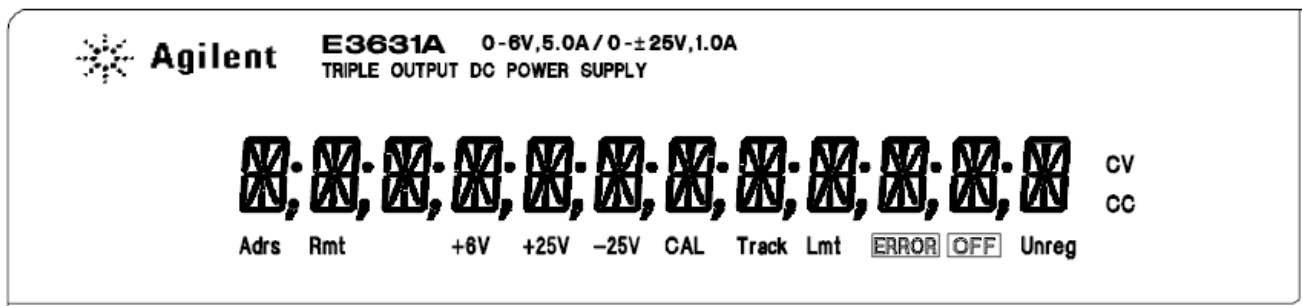

- Adrs** Power supply is addressed to listen or talk over a remote interface.
- Rmt** Power supply is in remote interface mode.
- +6V** Displays the output voltage and current for +6V supply. Knob is active for +6V supply.
- +25V** Displays the output voltage and current for +25V supply. Knob is active for +25V supply.
- 25V** Displays the output voltage and current for -25V supply. Knob is active for -25V supply.
- CAL** power supply is in calibration mode.
- Track** The outputs of +25V and -25V supplies are in track mode.
- Limit** The display shows the voltage and current limit value of a selected supply.
- ERROR** Hardware or remote interface command errors are detected and also the error bit has not been.
- OFF** The three outputs of the power supply are disabled.
- Unreg** The displayed output is unregulated (output is neither CV nor CC).
- CV** The displayed output is in constant-voltage mode.
- CC** The displayed output is in constant-current mode.