

33120A

Function Waveform Generator Operating Instructions

33120A Function Waveform Generator Operating Instructions

This pamphlet is intended to give you (the student) an overview on the use of the 33120A Function Waveform Generator. This pamphlet will instruct you on how to setup for different waveforms (sine, square, triangle, ramp) and how to set the frequency and amplitude of the waveforms.

Please visit the Agilent website <http://www.home.agilent.com/agilent/home> to view the complete user manual for more information.

Front Panel

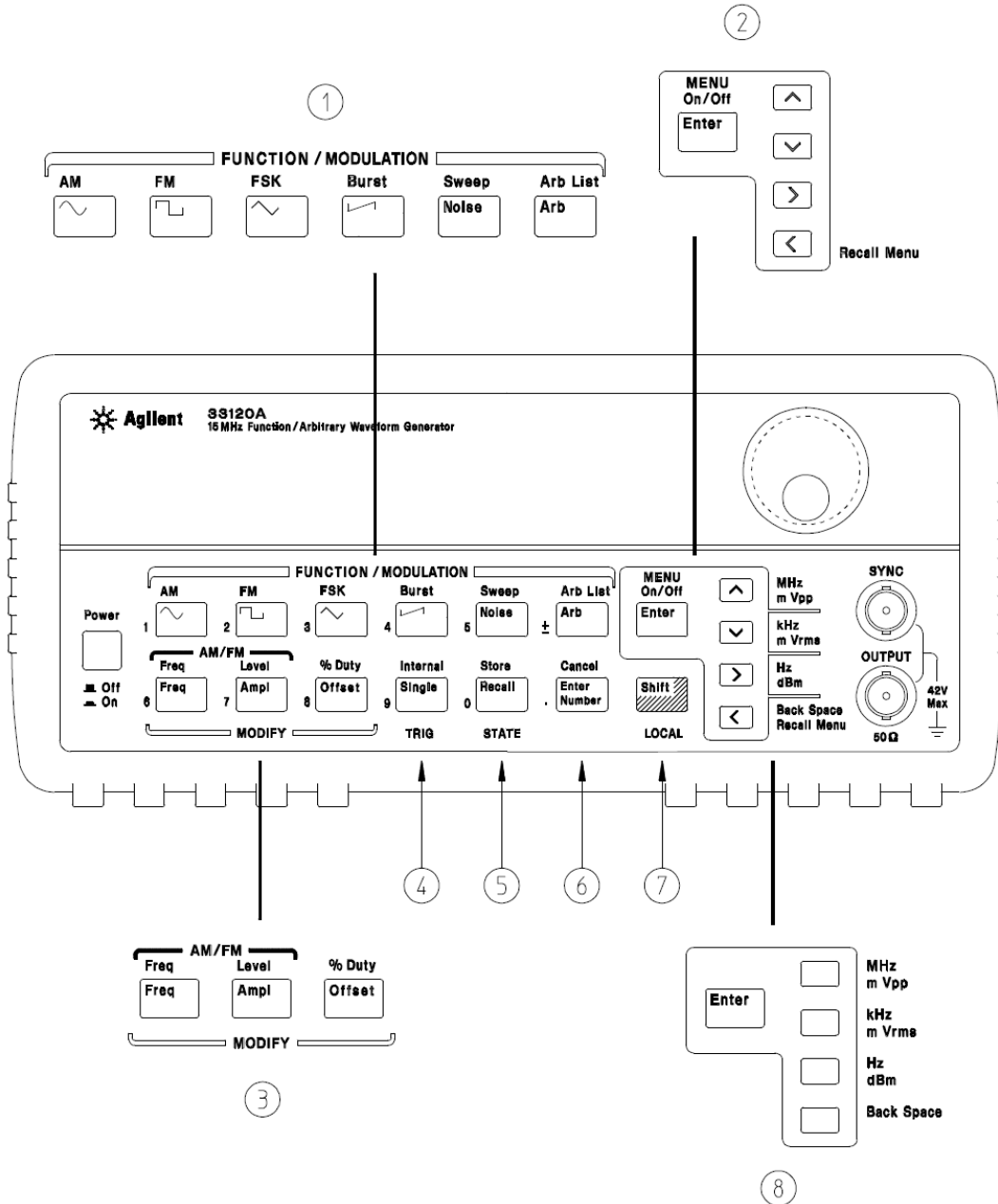

- 1 Function / Modulation keys
- 2 Menu operation keys
- 3 Waveform modify keys
- 4 Single / Internal Trigger key
(Burst and Sweep only)

- 5 Recall / Store instrument state key
- 6 Enter Number key
- 7 **Shift** / Local key
- 8 **Enter Number** "units" keys

Use the knob and the arrow keys to modify the displayed number.

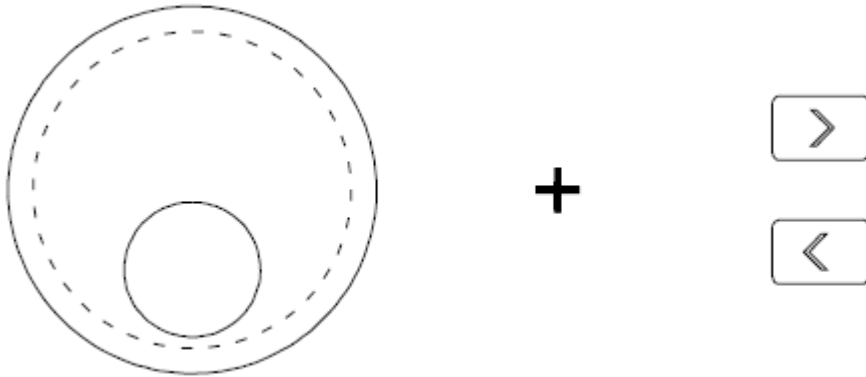

Use the arrow keys to edit individual digits.



Increments the flashing digit.



Decrements the flashing digit.



Moves the flashing digit **to the right**.



Moves the flashing digit **to the left**.

Use the “**Enter Number**” mode to enter a number with the appropriate units.

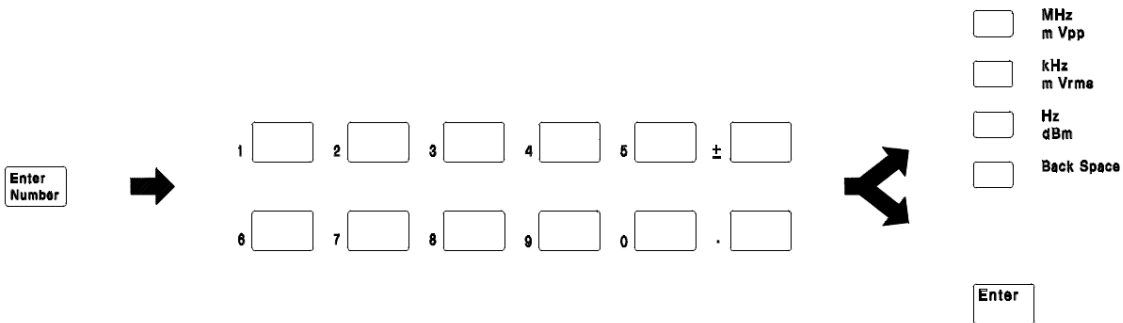

Use “Enter” for those operations that do not require units to be specified (AM Level, Offset, % Duty, and Store/Recall State).

Display Annunciators

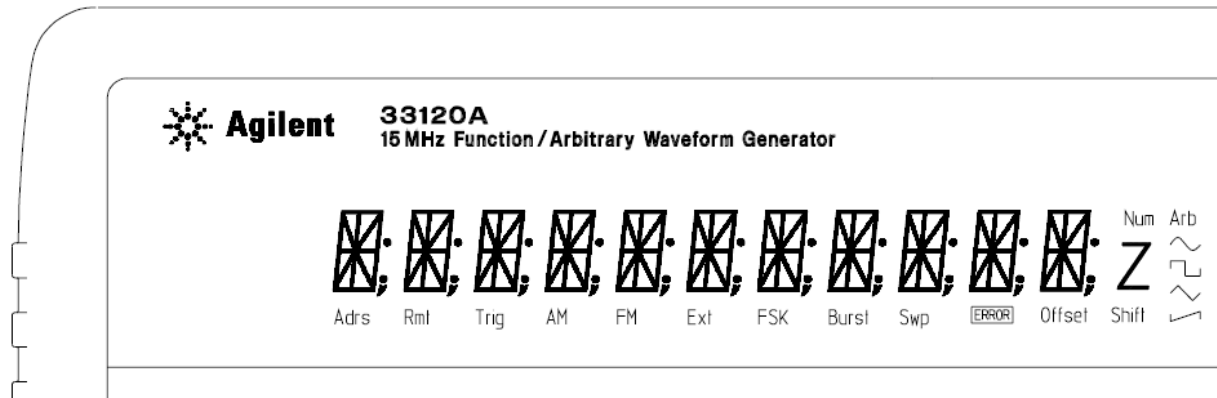

- Adrs** Function generator is addressed to listen or talk over a remote interface.
- Rmt** Function generator is in remote mode (remote interface).
- Trig** Function generator is waiting for a single trigger or external trigger (Burst, Sweep).
- AM** AM modulation is enabled.
- FM** FM modulation is enabled.
- Ext** Function generator is set for an external modulation source (AM, FSK, Burst).
- FSK** FSK (frequency-shift keying) modulation is enabled.
- Burst** Burst modulation is enabled.
- Swp** Sweep mode is enabled.
- ERROR** Hardware or remote interface command errors are detected.
- Offset** The waveform is being output with an offset voltage.
- Shift** "Shift" key has been pressed. *Press "Shift" again to turn off.*
- Num** "Enter Number" mode is enabled. *Press "Shift-Cancel" to disable.*
- Arb** Arbitrary waveform function is enabled.
- ~ Sine waveform function is enabled.
- Square waveform function is enabled.
- △ Triangle waveform function is enabled.
- ▽ Ramp waveform function is enabled.

The first things you will want to do with your function generator is become acquainted with the front panel.

There are four types of waveforms you may choose:

- ~ Sine waveform
- ▤ Square waveform
- ^ Triangle waveform
- ↘ Ramp waveform

The front panel has two rows of keys to select various functions and operations. Most keys have a *shifted* function printed in **blue** above the key. To perform a shifted function, press **Shift** (the **Shift** annunciator will turn on). Then, press the key that has the desired label above it. For example, to select the AM (amplitude modulation) function, press **Shift AM**  (the shifted version of the key).

If you accidentally press **Shift**, just press it again to turn off the **Shift** annunciator.

Most keys also have a number printed in **green** next to the key.

To enable the number mode, press **Enter Number** (the **Num** annunciator will turn on). Then, press the keys that have the desired numbers printed next to them. For example, to select the number “10”, press **Enter Number 1 0**  (next to the Recall keys).

If you accidentally press **Enter Number**, just press Shift Cancel to turn off the **Num** annunciator.

SYNC Signal

A sync signal output is provided on the front-panel *SYNC* terminal. All of the standard output functions (except dc and noise) have an associated sync signal. For certain applications where you may not want to output the sync signal you can disable the *SYNC* terminal.

To set the output frequency

When powered-on, the function generator outputs a sine wave at 1 kHz with an amplitude of 100 mV peak-to-peak (into a 50 Ω termination).

The following steps show you how to change the frequency to 1.2 MHz.

1 Enable the *frequency modify mode*.

The displayed frequency is either the power-on value or the previous frequency selected. When you change functions, the same frequency is used if the present value is valid for the new function.

1.000,000,0 KHz

2 Enter the magnitude of the desired frequency. 1.2

Notice that the **Num** annunciator turns on and “ENTER NUM” flashes on the display, indicating that the number mode is enabled.

Press **1.2**

*To cancel the number mode, press **Shift Cancel**.*

3 Set the units to the desired value. MHz m Vpp

The units are selected using the arrow keys on the right side of the front panel. As soon as you select the units, the function generator outputs the waveform with the displayed frequency. *To turn off the flashing digit, move the cursor to the left of the display using the arrow keys.*

1.200,000,0 MHz

You may also use the knob  or the arrow keys to set the desired frequency.

To set the output amplitude

At power-on, the function generator outputs a sine wave with an amplitude of 100 mV peak-to-peak (into a 50 Ω termination).

The following steps show you how to change the amplitude to 50 mVrms.

1 Enable the *amplitude modify mode*.

The displayed amplitude is either the power-on value or the previous amplitude selected. When you change functions, the same amplitude is used if the present value is valid for the new function.

100.0 mVPP

2 Enter the magnitude of the desired amplitude. 50

Notice that the **Num** annunciator turns on and "ENTER NUM" flashes on the display, indicating that the number mode is enabled.

Press **50**

*To cancel the number mode, press **Shift Cancel**.*

3 Set the units to the desired value. kHz m Vrms

The units are selected using the arrow keys on the right side of the front panel. As soon as you select the units, the function generator outputs the waveform with the displayed amplitude.

To turn off the flashing digit, move the cursor to the left of the display using the arrow keys.

50.00 mVRMS

You may also use the knob  or the arrow keys to set the desired amplitude.

To set a DC offset voltage

At power-on, the function generator outputs a sine wave with a dc offset voltage of 0 volts (into a 50 Ω termination).

*The following steps show you how to change the offset to **-1.5 mVdc**.*

1 Enable the *offset modify* mode.

The displayed offset voltage is either the power-on value or the previous offset selected. When you change functions, the same offset is used if the present value is valid for the new function.

+0.000 VDC

2 Enter the magnitude of the desired offset. 1.5

Notice that the **Num** annunciator turns on and “ENTER NUM” flashes on the display, indicating that the number mode is enabled.

Notice that toggles the displayed value between + and - .

Press **-1.5**

*To cancel the number mode, press **Shift Cancel**.*

3 Set the units to the desired value. kHz m Vrms

At this point, the function generator outputs the waveform with the displayed offset. Notice that the **Offset** annunciator turns on, indicating that the waveform is being output with an offset. The annunciator will turn on when the offset is any value other than 0 volts.

To turn off the flashing digit, move the cursor to the left of the display using the arrow keys.

-01.50 mVDC

You may also use the knob  or the arrow keys to set the desired offset.

To set the duty cycle

Applies only to square waves. At power-on, the duty cycle for square waves is 50%. You can adjust the duty cycle for a square waveform from 20% to 80%, in increments of 1% (for frequencies above 5 MHz, the range is 40% to 60%).

The following steps show you how to change the duty cycle to 45%.

1 Select the square wave function.



Notice that the  annunciator turns on, indicating that the square wave function is enabled.

2 Enable the *duty cycle modify* mode.



The displayed duty cycle is either the power-on value or the previous value selected.

50 % DUTY

This message appears on the display for approximately 10 seconds.

Repeat this step as needed.

3 Enter the desired duty cycle.

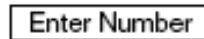

45



Notice that the **Num** annunciator turns on and “ENTER NUM” flashes on the display, indicating that the number mode is enabled.

Press **45**

*To cancel the number mode, press **Shift Cancel**.*

4 Output the waveform with the displayed duty cycle.

45 % DUTY

You may also use the knob  or the arrow keys   to set the desired duty cycle.