

THE DOOR IS OPEN

TRANSFER GUIDE FOR SULLIVAN COUNTY COMMUNITY COLLEGE STUDENTS

SUNY NEW PALTZ

Fourth Revision (2009)

This agreement is subject to review at the request of either party.

All information contained here-in is accurate as of the time this publication went to press. However, changes in program and other details may have occurred since that time, current information may be obtained from the office of the department concerned.

SUNY New Paltz supports affirmative action and equal opportunity and does not discriminate in educational programs or employment.

**STATE UNIVERSITY OF NEW YORK
NEW PALTZ**

Dear Student,

This booklet, THE DOOR IS OPEN, is the culmination of extensive consultations between the faculty and administration of Sullivan County Community College and SUNY New Paltz to develop a comprehensive transfer agreement between the two institutions.

Many programs at two-year colleges can and should lead into those at four-year institutions, especially within SUNY. For example, students who receive A.A., A.S., and in many instances an A.A.S. degree from Sullivan County Community College, should be able to complete their undergraduate study at New Paltz and earn a baccalaureate degree within a reasonable period of time. This transfer guide is designed to facilitate such an arrangement.

The DOOR IS OPEN was originally published in 1980 as the first comprehensive articulation agreement between Sullivan County Community College and SUNY New Paltz. We are very proud of the continued cooperative spirit in which the work has been undertaken, and we believe that this ongoing agreement will be of great benefit to Sullivan County Community College students who are considering transferring to SUNY New Paltz to complete a baccalaureate degree.

Mamie Howard Golladay
President
Sullivan County Community College

Steven Poskanzer
President
SUNY New Paltz

TABLE OF CONTENTS

QUESTIONS	5
<i>about transferring to New Paltz, and the use of this transfer guide</i>	
SUNY NEW PALTZ: A Brief Perspective	7
UNDERGRADUATE PROGRAMS	8
MAJOR PROGRAMS	
ANTHROPOLOGY.....	9
ART EDUCATION	9
ART HISTORY.....	10
ART STUDIO	10
ASIAN STUDIES.....	11
BIOLOGY.....	12
BLACK STUDIES.....	15
BUSINESS ADMINISTRATION	16
CHEMISTRY.....	18
COMMUNICATION DISORDERS	19
COMMUNICATION AND MEDIA.....	20
COMPUTER SCIENCE.....	21
ECONOMICS	22
EDUCATION.....	22
ELECTRICAL AND COMPUTER ENGINEERING	24
ENGLISH	26
FOREIGN LANGUAGES.....	28
GEOGRAPHY	28
GEOLOGICAL SCIENCES.....	29
HISTORY/SOCIAL STUDIES	31
INTERNATIONAL RELATIONS.....	32
JOURNALISM.....	33
LATIN AMERICAN STUDIES	33
MATHEMATICS.....	34
MUSIC	36
PHILOSOPHY.....	36
PHYSICS.....	37
POLITICAL SCIENCE.....	38
PRE-MEDICAL PROFESSIONS	39
PSYCHOLOGY	40
SOCIOLOGY.....	41
THEATER ARTS	41
WOMEN'S STUDIES.....	41
DISCLAIMER.....	43

QUESTIONS ABOUT TRANSFERRING TO NEW PALTZ, AND THE USE OF THIS TRANSFER GUIDE

Q. Does New Paltz offer the major I want?

A. New Paltz offers a wide variety of majors in both liberal arts and pre-professional programs, fine and performing arts, and education. Each major currently offered at New Paltz is listed in this Transfer Guide with Sullivan equivalent coursework. The full list of required coursework for each major appears in the New Paltz undergraduate catalog. This guide is designed for use in conjunction with the New Paltz catalog.

Q. Which of my Sullivan courses will transfer to New Paltz?

A. New Paltz accepts up to 70 credits from each Sullivan student.

An individual transfer credit evaluation will be provided to determine credits completed and credits still needed to meet the SUNY Mandated General Education requirement. Those A.A. and A.S. degree holders who complete courses in all ten knowledge and skill areas will be considered as having met the SUNY Mandated requirement. Prospective engineering majors must meet a different set of liberal arts requirements as part of the engineering curriculum in order to meet the ABET Accreditation Standards.

A.A.S holders generally have a larger number of non-liberal arts courses in their Sullivan program than A.A. or A.S. students. However, each applicant also receives an individual transfer credit evaluation with an assessment of credits completed and credits still needed to meet both general education requirements.

Q. Does this mean that an A.A.S. student can transfer to New Paltz? I thought that only A.A. and A.S. students could transfer?

A. A.A.S. degree holders can and do continue their studies at four-year colleges and universities, including New Paltz. Many liberal arts programs have strong career components, such as journalism, electronic media, and accounting.

In addition, many Sullivan A.A.S. programs fit well with the last two years of a New Paltz degree program. For example, students in criminal justice can pursue a political science or sociology major at New Paltz and complete requirements for a New Paltz degree within two additional years.

Q. What are the admission requirements?

All transfer students need a 2.75 GPA for consideration for all majors. The following majors have additional requirements:

Art (Studio) (2.75 and an Art Portfolio review)

Art Education (3.00 and an Art Portfolio review)

Early Childhood/Childhood Education (2.75 and 30 completed credits)

Communication Disorder (cumulative 3.0)

Mathematics (Completed up to Calculus I and be enrolled in Calculus II)

Music (Audition)

Psychology (“C” or better in General Psychology).

Adolescent Education (2.75 and “B” or better in Freshman Composition I and II)

Theatre (Audition)

Q. Which of my Sullivan courses will count toward my New Paltz major?

A. Using a current New Paltz catalog and this transfer guide this question can be easily answered. The Guide lists those courses required for each New Paltz major that can be taken at Sullivan. These courses will apply toward the requirements of each specific major as listed.

Q. How many of my Sullivan courses will count toward my New Paltz major?

A. As a general rule, one-half of the credits in the major must be completed at New Paltz. Please see the New Paltz catalog for details, www.newpaltz.edu/ugc.

Q. Can field service, independent study, and special topics courses taken at Sullivan be counted toward my major at New Paltz?

A. Field Service, Independent Study, and Special Topics may be acceptable toward a major pending review of appropriate documentation by the chairperson of the major department at SUNY New Paltz.

Q. Are all the courses I could take at Sullivan listed in this booklet?

A. No. This guide only lists those courses which are equivalent to courses required of a specific major at New Paltz. Courses at Sullivan that do not meet a major requirement are still transferable as “free” electives. The guide does not list major courses which are offered only at SUNY New Paltz.

Q. How can I be sure of which courses I still need to complete my major at New Paltz?

A. Each major, with the full list of courses required, is described in the most recent edition of the New Paltz undergraduate catalog, www.newpaltz.edu/ugc.

Q. What is the total number of credits required for a New Paltz degree?

A. New Paltz requires 120 academic credits for most of its degree programs. Among the 120 academic credits, a number of liberal arts credits are required for each specific degree.

90 for the Bachelor of Arts (B.A.)

60 for the Bachelor of Science (B.S.)

30 for the Bachelor of Fine Arts (B.F.A.)

48 for the Bachelor of Science (B.S.) in Art Education

NOTE: The Electrical and Computer Engineering Programs require a greater number of credits to complete the degree.

Liberal arts courses taken at Sullivan transfer towards this liberal arts requirement. Of the 120 academic credits, 45 must be upper-division level.

Q. What is the upper-division requirement?

A. Simply put, it is a requirement, common to many four-year colleges and universities, that a minimum number of credits be taken at an advanced level. At New Paltz, this consists of courses numbered at the 300, 400 and 500 levels. Each applicant to New Paltz receives a transfer credit evaluation which will summarize the number of credits, if any, which can transfer toward this requirement.

Q. What is the Writing Intensive requirement?

A. This requirement is separate from the General Education program. All students, including transfers with an A.A. or A.S. degree, must complete a three-credit New Paltz course, designated as Writing-Intensive, before graduation.

Q. How long will it take me to complete my program at New Paltz?

A. Normally, A.A. and A.S. degree holders from Sullivan when transferring to a parallel program, can complete their New Paltz degree in two additional

years of full-time successful study. However, if a complete change of major is made, it may take longer to complete the degree. Certain specialized fields such as electrical engineering and education, may require

additional studies beyond the normal four semesters. Finally, due to budgetary restrictions and increased demand for certain select majors, both native students and transfer students may, in some instances, require additional time in which to complete degree requirements because of more limited availability of certain coursework.

Q. Is there any additional information or advice available to me as a student transferring to New Paltz?

A. Yes, there are many sources. First, to help you make a well-informed decision, New Paltz provides an “Advisor in Residence” on the Sullivan campus one day each month to assist in the process of program planning and transfer. In addition, the Undergraduate Admissions Office provides all accepted applicants with a transfer credit evaluation. This evaluation summarizes the total number of credits which will be accepted in transfer to New Paltz, and shows specifically how your credits will be applied to general degree requirements.

You should also discuss your plans with a Sullivan advisor and the transfer/career planning and placement office at Sullivan.

Q. How do I obtain financial aid?

A. Financial Aid is available to eligible transfer students to help defray the costs of tuition, fees, room, and board at New Paltz. Information on how and when to apply for each of the available financial aid programs is sent to each transfer student at the time of acceptance.

Q. Is housing available on the New Paltz campus?

A. Yes. There are thirteen residence halls on the New Paltz campus. Four residence halls maintain a 24-hour quiet policy, which is a good arrangement for those students who prefer to study in their rooms rather than in the library.

Housing on campus can be very limited, so it is recommended that transfer students apply early and adhere to all application deadlines.

Some off-campus housing is available in the Village of New Paltz, but off-campus space in apartments and private homes is usually very difficult to obtain.

SUNY NEW PALTZ: A BRIEF PERSPECTIVE

Character:

Very competitive, 4 year co-ed, residential; regional university; state assisted; liberal arts/professional studies.

Founded: 1828

Location:

New Paltz, New York; small, historic village (pop. 8,600) in mid-Hudson region; midway between New York City and Albany.

Campus:

257 acres; 47 buildings. Sojourner Truth Library – 550,000 volumes

College Calendar:

Two, 14 week semesters, one summer session. Scheduled college closings - all college offices closed for state/federal holidays and weekends. Class schedule published online at: www.newpaltz.edu/classes. Weather delays and/or class cancellations posted online, at 845-257-INFO, and with regional media.

Enrollment (2008-2009):

Undergraduate: 6,707 - Full-time 5,150, Part-time 957,
Men 2,289, Women 4,418.
Graduate: 1,498 - Full-time 540, Part-time 958.

Student Geographic Distribution:

91% New York State, 6% Out-of-State, 3% International

Student Diversity:

5.5% Black/African-American, 9.5% Hispanic/Latino, 3.5% Asian/Pacific Islander; 0.2% American Indian/Alaska Native; 57.7% White/Caucasian; 4.5% Nonresident Alien; 19.2% Unreported Ethnicity.

Male/Female Ratio:

2,289 M (34%) – 4,418 W (66%)

Academic Structure:

College of Liberal Arts and Science
School of Business
School of Science and Engineering
School of Fine and Performing Arts
School of Education
The Graduate School at New Paltz

Accreditations:

Middle States Association of Colleges and Secondary Schools
New York State Education Department
Accreditation Board for Engineering and Technology
American Chemical Society
American Speech-Language and hearing Association
Computer Sciences Accreditation Board
National Association of Music Therapy (Master's degree)
National Association of Schools of Art
National Association of Schools of Music
National Association of Schools of Theatre
National Council for Accreditation of Teacher Education

Faculty:

335 Full-time
387 Part-time
82% hold Ph.D. or terminal degree
Student/Faculty Ratio: 15-1

Average Class Size:

77% of classes are less than 30 students
92.5% of classes are less than 40 students

Residence Life:

13 residence halls (2,800 capacity)

NCAA Division III Athletics:

Baseball (M)
Soccer (M/W)
Basketball (M/W)
Softball (W)
Cross Country (M/W)
Swimming (M/W)
Field Hockey (W)
Tennis (W)
Lacrosse (W)
Volleyball (M/W)

Student Activities: 1

30 student organizations, 800 student leadership positions

Admission:

Very Selective

Freshmen:

High School Average - Middle 50%: 87 - 93
SAT Verbal/Math Composite - Middle 50%:
1040 – 1240

Transfer:

Average Transfer GPA: 3.35

UNDERGRADUATE PROGRAMS

COLLEGE OF LIBERAL ARTS & SCIENCES

Anthropology
Asian Studies
Black Studies
Communication
 Public Communication*
 Organizational Communication*
 Interpersonal/Intercultural
 Communication
 Public Relations*
Communication Disorders
Economics
 Business Economics*
 International Economics*
Electronic Media
English
 Creative Writing*
Foreign Languages
 French
 Spanish
Geography
History
 Jewish Studies*
International Relations
Journalism
Latin American Studies
Philosophy
 Religious Studies*
Political Science
Psychology
 Psychobiology*
Sociology
 Direct Care*
Women's Studies

SCHOOL OF EDUCATION

Early Childhood Education (B-2)
Childhood Education (1-6)
Adolescence Education (7-12)
 Biology
 Chemistry
 Earth Science
 English
 French
 Mathematics
 Physics
 Social Studies
 Spanish

SCHOOL OF FINE AND PERFORMING ARTS

Art
 Ceramics (BFA)
 Graphic Design (BFA)
 Metals (BFA)
 Painting (BFA)
 Photography (BFA)
 Printmaking (BFA)
 Sculpture (BFA)
Art Education
Art History
Music
 History & Literature*
 Performance*
 Music Theory & Composition*
 Jazz Studies*
Scenography (BFA)
Theatre Arts
 Performance*
 Design/Technical Studies*
Visual Arts

SCHOOL OF BUSINESS ADMINISTRATION

Accounting
General Business
Finance
International Business
Marketing
Management

SCHOOL OF PHYSICAL SCIENCES AND ENGINEERING

Biology
 Organismal & Environmental
 Biology*
 Cell/Molecular Biology &
 Biotechnology*
 Pre-Health Sciences Advising
 BS/MS Environmental Science
 Program with SUNY ESF
Chemistry
 Biochemistry*
 Biotechnology*
Computer Engineering
Computer Science
Electrical Engineering
Environmental Geochemical Science
Geology
 Environmental Geoscience*
 Environmental Earth Science*
Mathematics
Physics

MINORS

Art
Arts Administration
Asian Studies
Astronomy
Catskill Mountain &
 Hudson River Studies
Environmental Science
Italian Studies
Jewish Studies
Law and Politics
Linguistics
Native American Studies
Religious Studies
Russian Language & Literature
Russian Studies
Urban Studies

***Concentration within the major**

MAJOR PROGRAMS

The major programs listed in the sections that follow show the courses a student may take at Sullivan County Community College and which may also be applied to the major at New Paltz. In addition, most of the Sullivan courses not listed here will be accepted in transfer by New Paltz as general elective credit toward the degree. Remedial/developmental courses do not transfer.

Within existing majors a number of emphases further extend student choices. For example, within the English major a student may select the comparative literature or creative writing track. The communications major may select a concentration in public communication, organizational communication, interpersonal-intercultural communication, or electronic media. Music majors may concentrate in applied music, music history and literature, and music theory and composition. Geological sciences offer an applied/environmental geology option. Within chemistry a biochemistry emphasis is available, and in the business program concentrations in management, marketing, finance, or international business are available, as well as a CPA approved accounting major. Students should consult the New Paltz catalog for details of other major programs.

ANTHROPOLOGY

The New Paltz Anthropology Department offers a range of coursework dealing with the evolution of humans, the development and diversity of human cultures, as well as the study of family and social organizations, political systems, and religious systems. The department also sponsors a seven-week field study for students to participate in an actual archaeological excavation.

Students may pursue a major or minor in Anthropology in the College of Liberal Arts & Science. They may also select Anthropology courses to be used towards the adolescence (7-12) education social studies major. See New Paltz catalog for details.

One-half of the credits in the major must be completed at New Paltz.

SULLIVAN COURSES

EQUIVALENT NEW PALTZ COURSE

SBS 1102 Social Anthropology

ANT 214 Cultural Anthropology

Sullivan courses not listed above may be accepted in transfer by New Paltz as general elective credit toward the degree with the exception of those courses which are remedial/developmental in nature.

ART EDUCATION

The Art Education Department offers a program leading to the Bachelors of Science degree. Upon completion of the program, students are eligible for initial New York State certification to teach art in the public schools, grades K-12.

The Art Education program provides a concentration, which includes work in studio art and art history, child and adolescent psychology, curriculum development, philosophical and theoretical approaches to art education, and critical and evaluative analysis in art education. See the New Paltz catalog for details.

Prospective Art Education majors must have a 2.75 grade point average and submit an Art Portfolio.

One-half of the credits in the major must be completed at New Paltz.

SULLIVAN COURSES

EQUIVALENT NEW PALTZ COURSE

ART 1001 Drawing I

ARS 100 Drawing I: Visual Thinking I

ART 1205 Design and Color

ARS 102 Integrated Design I: Space and Form

ARS 101 Drawing II: Visual Thinking II, ARS 103 Integrated Design II: Forces, ARH 201 Art of the Western World I and ARH 202 Art of the Western World II must be taken at New Paltz to complete the required introductory courses.

A grade of 'B' is required for each course in the foundation sequence (Drawing I: Visual Thinking I, Drawing II: Visual Thinking II, Integrated Design I: Space and Form, Integrated Design II: Force).

In addition, art education students must complete a series of courses in education, art education, and a specialization in art. See New Paltz catalog for details. Art Education courses are not available at Sullivan, and must be taken at New Paltz. Some of the art studio courses which comprise the specialization in art may be taken at Sullivan. See section on ART STUDIO for details.

Sullivan courses not listed above may be accepted in transfer by New Paltz as general elective credit toward the degree with the exception of those courses which are remedial/developmental in nature.

ART HISTORY

The Department of Art History offers courses in the history of painting, sculpture, architecture, graphic and decorative arts, design, photography and film. A major in this department requires 33 credits of Art History courses and leads to the B.A. degree. Students contemplating advanced study in art history are strongly urged to take a foreign language, preferably French or German.

Students in the B-2 Early Childhood and 1-6 Childhood Education programs may select an Art History concentration as part of the education curriculum. See the New Paltz catalog for details.

One-half of the credits in the major must be completed at New Paltz.

SULLIVAN COURSES

EQUIVALENT NEW PALTZ COURSE

HUM 1110 20th Century Art

ARH 358 Early 20th Century Art

ARH 201 Art History I and ARH 202 Art of the Western World II must be taken at New Paltz to complete the required introductory courses.

Sullivan courses not listed above may be accepted in transfer by New Paltz as general elective credit toward the degree with the exception of those courses which are remedial/developmental in nature.

ART STUDIO

Students seeking an undergraduate degree in art may pursue one of the following programs:

(1) Bachelor of Fine Arts (B.F.A.) in Art Studio, with a concentration in either ceramics, metal, painting, printmaking, graphic design, photography, or sculpture. (2) Bachelor of Arts (BA) or Bachelor of Science (B.S.) in Visual Arts. The program is served by a large staff of practicing artists.

SUNY New Paltz courses numbering ARS 100, ARS 102, ARS 103, and ARS 101 are requirements common to all of the above programs. The remaining courses listed here are required or electives depending upon the concentration the student selects. See New Paltz catalog for details.

Prospective Art Education majors must have a 2.75 grade point average and submit an Art Portfolio.

One-half of the credits in the major must be completed at New Paltz.

SULLIVAN COURSES

EQUIVALENT NEW PALTZ COURSE

Required courses for all art majors:

ART 1001 Drawing I

ART 1205 Design and Color

HUM 1110 20th Century Art

ARS 100 Drawing I: Visual Thinking I

ARS 102 Integrated Design I: Space and Form

ARH 358 Early 20th Century Art

ARS 101 Drawing II: Visual Thinking II, ARS 103 Integrated Design II: Forces, ARH 201 Art of the Western World I and ARH 202 Art of the Western World II must be taken at New Paltz to complete the required introductory courses.

A grade of 'B' is required for each course in this foundation sequence (Drawing I: Visual Thinking I, Drawing II: Visual Thinking II, Integrated Design I: Space and Form, Integrated Design II: Force).

Select courses based on a specific art concentration:

ART 1601 Introduction to Typography*

ART 1610 Computer Graphics I*

ART 2001 Drawing II*

ART 2610 Computer Graphics II*

ART 2630 Graphic Design

ART 2710 Computer Graphics III*

PHO 1405 Photography I*

PHO 2405 Photography II*

PHO 2420 Commercial Photography*

PHO 2450 Studio Photography*

PHO 2500 Photography as Illustration*

PHO 2601 Digital Imaging I*

PHO 2701 Digital Imaging II*

No corresponding course*

ARS 205 Computer Aided Graphic Design*

No corresponding course*

No corresponding course*

No corresponding course*

No corresponding course*

ARS 250 Basic Photography*

No corresponding course*

No corresponding course*

No corresponding course*

No corresponding course*

ARS 308 Digital Photographic Imaging*

No corresponding course*

***REVIEW REQUIRED:** All courses taken beyond the freshman year sequence must be reviewed by appropriate option faculty through portfolio submission prior to equivalency credit being granted. Coursework not so credited will be considered art electives or general elective credit toward the degree. See Transfer Art Portfolio information.

Sullivan courses not listed above may be accepted in transfer by New Paltz as general elective credit toward the degree with the exception of those courses which are remedial/developmental in nature.

ASIAN STUDIES

Although Sullivan does not offer an Asian Studies major, an Asian Studies major is available at New Paltz for those transfer students who wish to pursue one.

The major and minor in Asian Studies is designed to provide students with a broad working knowledge of the region's history, geography, language and culture. Students pursuing this major will embark on 36 credits of interdisciplinary courses offered through the following departments: Anthropology, English, Foreign Language, Geography, History, Philosophy, and Political Science. Students are also required to complete at least two years of Chinese or Japanese language.

The minor consists of 18 credits and at least one year of either language, along with courses selected through advisement.

One-half of the credits in the major must be completed at New Paltz.

SULLIVAN COURSES**EQUIVALENT NEW PALTZ COURSE**

SBS 1287 Introduction to East Asia*

No corresponding course*

May be used as elective credit toward the New Paltz Asian Studies major where applicable.Sullivan courses not listed above may be accepted in transfer by New Paltz as general elective credit toward the degree with the exception of those courses which are remedial/developmental in nature.***BIOLOGY**

Biology encompasses a number of fields that range from molecular and cell biology on one hand to environmental studies and animal behavior on the other. In addition to extensive classroom and laboratory facilities, the Biology Department maintains both scanning and transmission electron microscope facilities. The surrounding area provides an excellent setting for field biology courses.

Students may major in liberal arts Biology with concentrations in (1) Organismal/Environmental Biology, (2) Cell/Molecular Biology and Biotechnology, or they may select a biology major in childhood or adolescence education programs. Any of the liberal arts biology major concentrations provide the necessary course work for entrance into the pre-medical professions. (See PRE-MEDICAL PROFESSIONS section of this booklet).

The New Paltz courses numbered BIO 201 and BIO 202 are required for any of the above major programs. The other courses listed are electives or required for the major, depending upon the specific program. See New Paltz catalog for details.

*One-half of the credits in the major must be completed at New Paltz.***SULLIVAN COURSES****EQUIVALENT NEW PALTZ COURSE**

SCI 1124 Principles of Biology I	}	_____	BIO 201 General Biology I
AND			
SCI 1125 Principles of Biology I Lab	}	_____	BIO 202 General Biology II
SCI 2152 Principles of Biology II			
AND			
SCI 2153 Principles of Biology II Lab	}	_____	BIO 350 General Microbiology
SCI 1122 Microbiology			
AND	}	_____	BIO 320 Genetics
SCI 1123 Microbiology Laboratory			
SCI 1141 Genetics	}	_____	CHE 201 General Chemistry I
AND			
SCI 1142 Genetics Laboratory	}	_____	CHE 202 General Chemistry II
SCI 1202 General Chemistry I			
AND			
SCI 1203 General Chemistry I Lab	}	_____	CHE 318 Organic Chemistry I
SCI 2202 General Chemistry II			
AND	}	_____	CHE 319 Organic Chemistry II
SCI 2203 General Chemistry II Lab			
SCI 2208 Organic Chemistry I	}	_____	MAT 241 Introductory Statistics
AND			
SCI 2209 Organic Chemistry I Lab	}	_____	MAT 251 Calculus I
SCI 2210 Organic Chemistry II			
AND	}	_____	
SCI 2211 Organic Chemistry II Lab			
MAT 2501 Elementary Statistics			
MAT 1301 Analytical Geometry and Calculus I			

Select one:

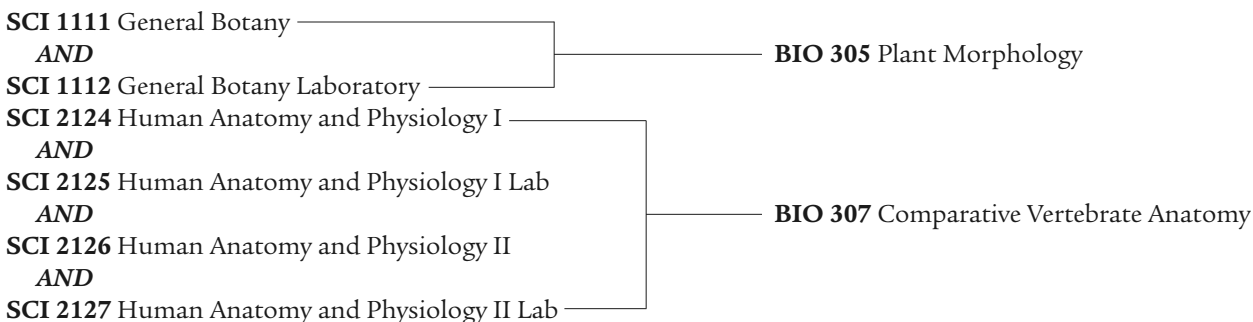

Electives:

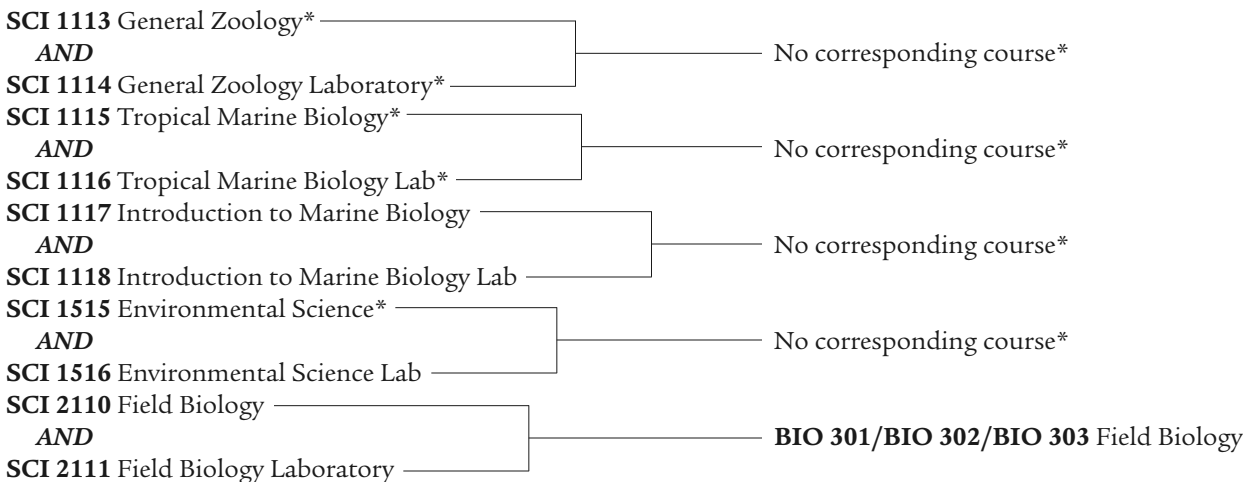

*May be used as elective credit toward the New Paltz Biology major where applicable.

EARLY CHILDHOOD (B-2)/CHILDHOOD (1-6) BIOLOGY

One-half of the credits in the liberal art major/concentration must be completed at New Paltz.

SULLIVAN COURSES

EQUIVALENT NEW PALTZ COURSE

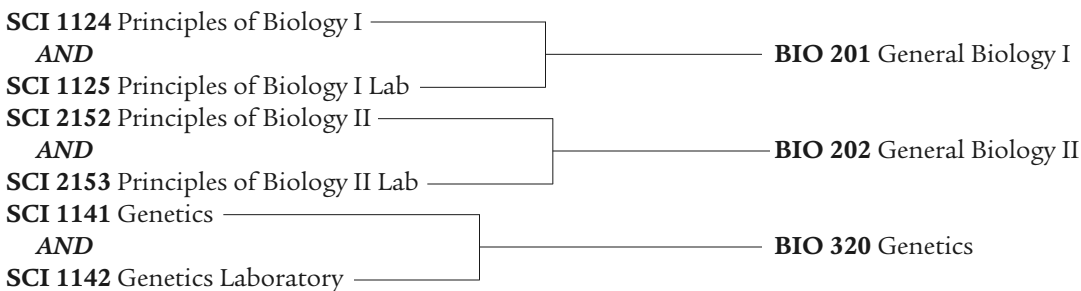

Select one:

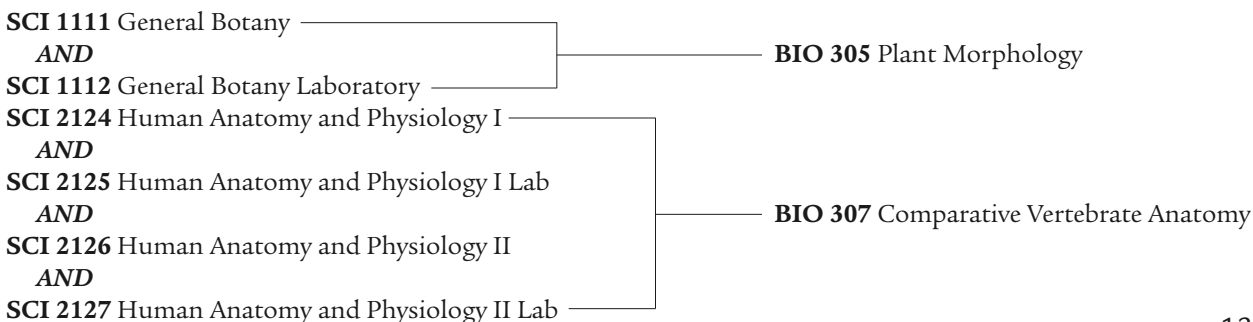

Select one elective:

SCI 1110 Ornithology	BIO 381 Introduction to Ornithology
SCI 1113 General Zoology*	No corresponding course*
AND	
SCI 1114 General Zoology Laboratory*	No corresponding course*
AND	
SCI 1115 Tropical Marine Biology*	No corresponding course*
AND	
SCI 1116 Tropical Marine Biology Lab*	No corresponding course*
AND	
SCI 1117 Introduction to Marine Biology	No corresponding course*
AND	
SCI 1118 Introduction to Marine Biology Lab	BIO 350 General Microbiology
AND	
SCI 1122 Microbiology	No corresponding course*
AND	
SCI 1123 Microbiology Laboratory	No corresponding course*
AND	
SCI 1515 Environmental Science*	No corresponding course*
AND	
SCI 1516 Environmental Science Lab	BIO 301/BIO 302/BIO 303 Field Biology
AND	
SCI 2110 Field Biology	No corresponding course*
AND	
SCI 2111 Field Biology Laboratory	

ADOLESCENCE (7-12) BIOLOGY

One-half of the credits in the liberal art major/concentration must be completed at New Paltz.

SULLIVAN COURSES

EQUIVALENT NEW PALTZ COURSE

SCI 1124 Principles of Biology I	No corresponding course*
AND	
SCI 1125 Principles of Biology I Lab	BIO 201 General Biology I
AND	
SCI 2152 Principles of Biology II	No corresponding course*
AND	
SCI 2153 Principles of Biology II Lab	BIO 202 General Biology II
AND	
SCI 1141 Genetics	No corresponding course*
AND	
SCI 1142 Genetics Laboratory	BIO 320 Genetics
AND	
SCI 1202 General Chemistry I	No corresponding course*
AND	
SCI 1203 General Chemistry I Lab	CHE 201 General Chemistry I
AND	
SCI 2202 General Chemistry II	No corresponding course*
AND	
SCI 2203 General Chemistry II Lab	CHE 202 General Chemistry II
AND	
SCI 2208 Organic Chemistry I	No corresponding course*
AND	
SCI 2209 Organic Chemistry I Lab	CHE 318 Organic Chemistry I
AND	
SCI 2210 Organic Chemistry II	No corresponding course*
AND	
SCI 2211 Organic Chemistry II Lab	CHE 319 Organic Chemistry II
AND	
MAT 1301 Analytical Geometry and Calculus I	MAT 251 Calculus I

Select one:

CPT 2929 Introduction to C++ and Object Oriented Programming	CPS 210 Computer Science I: Foundations
MAT 2501 Elementary Statistics	MAT 241 Introductory Statistics
MAT 2301 Analytical Geometry and Calculus II	MAT 252 Calculus II

Select one:

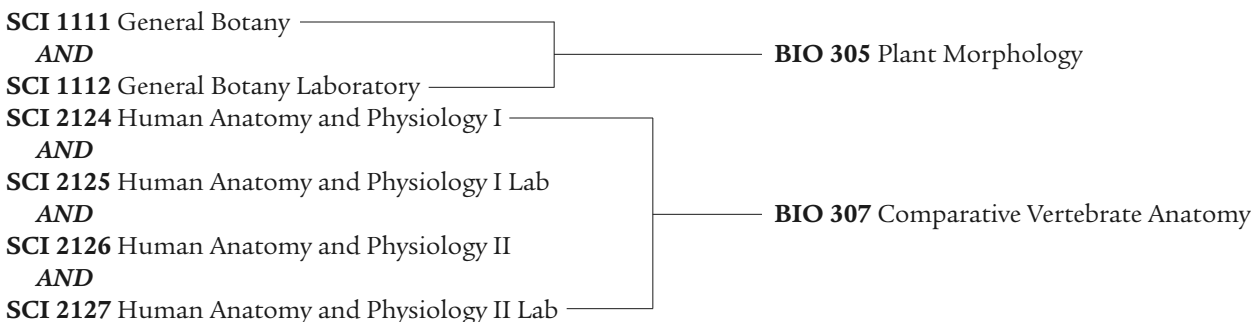

Sullivan courses not listed above may be accepted in transfer by New Paltz as general elective credit toward the degree with the exception of those courses which are remedial/developmental in nature.

BLACK STUDIES

The Black Studies Department seeks to provide a more thorough and accurate treatment of the history of Black people in America. It examines the impact of current economic, social and political forces that shape the Black experience and contributes to a basic understanding of the special problems faced by Black people in contemporary American life. The major provides an opportunity to study the artistic expressions of Black people, for research and creative activity in Black studies both on campus and in the community. In its comprehensive approach, and as a complement to more traditional majors, the Department of Black Studies seeks to prepare students for most professional careers outside the science fields.

Students in the B-2 Early Childhood and 1-6 Childhood Education programs may select a Black Studies history or literature concentration as part of the education curriculum. See New Paltz catalog for details.

One-half of the credits in the major must be completed at New Paltz.

SULLIVAN COURSES

EQUIVALENT NEW PALTZ COURSE

SBS 1223 History of Africa*

SBS 1224 The History of African-American*

ENG 2007 South African Literature*

ENG 2926 Black Literature in America*

BLS 200 Introduction to Africa*

BLS 202 Black History II*

No corresponding course*

BLS 267 Survey of Black-American Literature*

*May be used as elective credit toward the New Paltz Black Studies major where applicable.

Sullivan courses not listed above may be accepted in transfer by New Paltz as general elective credit toward the degree with the exception of those courses which are remedial/developmental in nature.

BUSINESS ADMINISTRATION

The School of Business at SUNY New Paltz offers the Bachelor of Science (B.S.) in Accounting, Finance, General Business, International Business, Management, and Marketing. These degree programs are designed to meet the demand for qualified graduates to work in today's global marketplace.

All students must take the Core Requirements (39 credits) and have a Math Proficiency Level (MPL) of at least 4. The MPL 4 courses at Sullivan are MAT1003 College Mathematics II or MAT1205 Intermediate Algebra and Trigonometry.

Some courses have prerequisites of which students must be aware. The Accounting degree requires 24 major credits for a total of 63 degree credits. The General Business, International Business and Marketing degrees

require 20 major credits for a total of 60 degree credits. The Finance and Management degrees require 18 major credits for a total of 57 degree credits.

Acceptance as a major in the School of Business is based upon overall academic performance as well as performance in selected courses. Transfer students should be aware that (1) the university requires at least one-half of the courses in the major be completed at SUNY New Paltz and (2) transfer business courses which are given graduation credit by the university may not necessarily satisfy the business requirement. See the New Paltz catalog for details. See the New Paltz catalog for details.

One-half of the credits in the major must be completed at New Paltz.

SULLIVAN COURSES

EQUIVALENT NEW PALTZ COURSE

BUS 1302 Principles of Advertising*	No corresponding course*
BUS 1304 Principles of Salesmanship*	No corresponding course*
BUS1652 Human Resource Management*	No corresponding course*
BUS 2602 Introduction to International Business*	No corresponding course*

**May be used as elective credit toward the New Paltz Business major where applicable. BUS 345 Human Resource Management and BUS 346 International Business must be completed at New Paltz.*

BACHELOR OF SCIENCE IN ACCOUNTING

SULLIVAN COURSES

EQUIVALENT NEW PALTZ COURSE

SBS 1401 Macroeconomics	ECO 207 Macroeconomics
SBS 1402 Microeconomics	ECO 206 Microeconomics
BUS 1301 Principles of Marketing	BUS 325 Marketing
BUS 1310 Principles of Management	BUS 250 Principles of Management
BUS 1416 Financial Accounting	BUS 201 Financial Accounting
BUS 1501 Business Law I	BUS 271 Legal Environment of Business
BUS 2502 Business Law II	BUS 272 Business Law for Accountants
BUS 2416 Managerial Accounting	BUS 202 Managerial Accounting

BACHELOR OF SCIENCE IN FINANCE

SULLIVAN COURSES

EQUIVALENT NEW PALTZ COURSE

SBS 1401 Macroeconomics	ECO 207 Macroeconomics
SBS 1402 Microeconomics	ECO 206 Microeconomics
BUS 1301 Principles of Marketing	BUS 325 Marketing
BUS 1310 Principles of Management	BUS 250 Principles of Management
BUS 1416 Financial Accounting	BUS 201 Financial Accounting
BUS 1501 Business Law I	BUS 271 Legal Environment of Business
BUS 2416 Managerial Accounting	BUS 202 Managerial Accounting

BACHELOR OF SCIENCE IN GENERAL BUSINESS

SULLIVAN COURSES

EQUIVALENT NEW PALTZ COURSE

SBS 1401 Macroeconomics	ECO 207 Macroeconomics
SBS 1402 Microeconomics	ECO 206 Microeconomics
BUS 1301 Principles of Marketing	BUS 325 Marketing
BUS 1310 Principles of Management	BUS 250 Principles of Management

BUS 1416 Financial Accounting
BUS 1501 Business Law I
BUS 2416 Managerial Accounting

BUS 201 Financial Accounting
BUS 271 Legal Environment of Business
BUS 202 Managerial Accounting

BACHELOR OF SCIENCE IN INTERNATIONAL BUSINESS

SULLIVAN COURSES

EQUIVALENT NEW PALTZ COURSE

SBS 1401 Macroeconomics
SBS 1402 Microeconomics
BUS 1301 Principles of Marketing
BUS 1310 Principles of Management
BUS 1416 Financial Accounting
BUS 1501 Business Law I
BUS 2416 Managerial Accounting

ECO 207 Macroeconomics
ECO 206 Microeconomics
BUS 325 Marketing
BUS 250 Principles of Management
BUS 201 Financial Accounting
BUS 271 Legal Environment of Business
BUS 202 Managerial Accounting

NOTE: Language proficiency through the Intermediate II Level in one language is required in this concentration. Sullivan offers a four semester sequence in the following languages: French and Spanish.

Students in the International Business concentration must select three courses in a given region of the world to meet the Area Studies Elective category. As much as is possible, the courses in this category should be consistent with the foreign language selected to meet International Business concentration requirements. See the New Paltz catalog for a complete listing of Area Studies courses.

BACHELOR OF SCIENCE IN MANAGEMENT

SULLIVAN COURSES

EQUIVALENT NEW PALTZ COURSE

SBS 1401 Macroeconomics
SBS 1402 Microeconomics
BUS 1301 Principles of Marketing
BUS 1310 Principles of Management
BUS 1416 Financial Accounting
BUS 1501 Business Law I
BUS 2416 Managerial Accounting

ECO 207 Macroeconomics
ECO 206 Microeconomics
BUS 325 Marketing
BUS 250 Principles of Management
BUS 201 Financial Accounting
BUS 271 Legal Environment of Business
BUS 202 Managerial Accounting

BACHELOR OF SCIENCE IN MARKETING

SULLIVAN COURSES

EQUIVALENT NEW PALTZ COURSE

SBS 1401 Macroeconomics
SBS 1402 Microeconomics
BUS 1301 Principles of Marketing
BUS 1310 Principles of Management
BUS 1416 Financial Accounting
BUS 1501 Business Law I
BUS 2416 Managerial Accounting

ECO 207 Macroeconomics
ECO 206 Microeconomics
BUS 325 Marketing
BUS 250 Principles of Management
BUS 201 Financial Accounting
BUS 271 Legal Environment of Business
BUS 202 Managerial Accounting

Sullivan courses not listed above may be accepted in transfer by New Paltz as general elective credit toward the degree with the exception of those courses which are remedial/developmental in nature.

CHEMISTRY

The Chemistry Department at New Paltz offers many advantages to the student interested in majoring in this field. It provides a strong background in general, organic, physical, and analytical chemistry, and offers a variety of courses not generally available at four-year colleges. New Paltz upper-division undergraduates are able to enroll in advanced courses in biochemistry, materials science, and instrumentation. High quality modern equipment is used for instruction and research in student laboratories. The small size of upper-division courses encourages close interaction between faculty and students. In addition, the chemistry faculty sponsor student research.

Two undergraduate programs leading to liberal arts degrees are available: the American Chemical Society (ACS) approved major and a general chemistry major. There are also concentrations in biochemistry and biotechnology. In addition, students in the adolescence (7-12) teacher certification program may select a chemistry major as part of the education curriculum. See the New Paltz catalog for details.

One-half of the credits in the major must be completed at New Paltz.

SULLIVAN COURSES	EQUIVALENT NEW PALTZ COURSE
SCI 1202 General Chemistry I AND SCI 1203 General Chemistry I Lab	CHE 201 General Chemistry I
SCI 2202 General Chemistry II AND SCI 2203 General Chemistry II Lab	CHE 202 General Chemistry II
SCI 2208 Organic Chemistry I AND SCI 2209 Organic Chemistry I Lab	CHE 318 Organic Chemistry I
SCI 2210 Organic Chemistry II AND SCI 2211 Organic Chemistry II Lab	CHE 319 Organic Chemistry II
SCI 1302 Calculus Physics I - Mechanics AND SCI 1303 Calculus Physics I Lab	PHY 201 General Physics I
SCI 2302 Calculus Physics II AND SCI 2303 Calculus Physics II Lab	PHY 201 General Physics I
MAT 1301 Analytical Geometry and Calculus I MAT 2301 Analytical Geometry and Calculus II	MAT 251 Calculus I MAT 252 Calculus II
<i>Biochemistry Emphasis only:</i>	
SCI 1124 Principles of Biology I AND SCI 1125 Principles of Biology I Lab	BIO 201 General Biology I
SCI 2152 Principles of Biology II AND SCI 2153 Principles of Biology II Lab	BIO 202 General Biology II
SCI 1141 Genetics AND SCI 1142 Genetics Laboratory	BIO 320 Genetics
<i>Biotechnology Emphasis only:</i>	
SCI 1124 Principles of Biology I AND SCI 1125 Principles of Biology I Lab	BIO 201 General Biology I

SCI 1122 Microbiology	—	—	BIO 350 General Microbiology
AND			
SCI 1123 Microbiology Laboratory	—	—	BIO 320 Genetics
AND			
SCI 1141 Genetics	—	—	BIO 320 Genetics
AND			
SCI 1142 Genetics Laboratory	—	—	BIO 320 Genetics
AND			

**May be used as an elective credit toward the New Paltz Chemistry major where applicable.*

ADOLESCENCE (7-12) CHEMISTRY

One-half of the credits in the liberal art major/concentration must be completed at New Paltz.

SULLIVAN COURSES	EQUIVALENT NEW PALTZ COURSE
SCI 1202 General Chemistry I	CHE 201 General Chemistry I
AND	
SCI 1203 General Chemistry I Lab	CHE 202 General Chemistry II
AND	
SCI 2202 General Chemistry II	CHE 318 Organic Chemistry I
AND	
SCI 2203 General Chemistry II Lab	CHE 319 Organic Chemistry II
AND	
SCI 2208 Organic Chemistry I	BIO 201 General Biology I
AND	
SCI 2209 Organic Chemistry I Lab	GLG 220 Physical Geology
AND	
SCI 2210 Organic Chemistry II	PHY 201 General Physics I
AND	
SCI 2211 Organic Chemistry II Lab	PHY 202 General Physics II
AND	
SCI 1124 Principles of Biology I	MAT 251 Calculus I
AND	
SCI 1125 Principles of Biology I Lab	MAT 252 Calculus II
AND	
SCI 1018 Physical Geology	
AND	
SCI 1019 Physical Geology Laboratory	
SCI 1302 Calculus Physics I - Mechanics	
AND	
SCI 1303 Calculus Physics I Lab	
SCI 2302 Calculus Physics II	
AND	
SCI 2303 Calculus Physics II Lab	
MAT 1301 Analytical Geometry and Calculus I	
MAT 2301 Analytical Geometry and Calculus II	

Sullivan courses not listed above may be accepted in transfer by New Paltz as general elective credit toward the degree with the exception of those courses which are remedial/developmental in nature.

COMMUNICATION DISORDERS

The Department of Communication Disorders offers two major programs: a liberal arts major and a speech education major. The liberal arts major (588) requires 48 credits and prepares students for graduate study in speech-language pathology, audiology, and related areas. The speech education major (788) has just been re-registered to meet the new New York state requirements for the Initial Certificate as a Teacher of Students with Speech and Language Disabilities. This unique program is linked to the graduate program in Speech-Language Pathology. Please see the New Paltz catalog for details.

All students must enter the liberal arts major (588) initially, usually in the fall semester of the junior year. The minimum GPA for declaration of the major is 2.8. (If the GPA is between 2.5 and 2.8, the student may request permission from the Department Chair to take the fall core courses). Admission to the Certification track major (788) is by application only during the spring of the junior year.

Prospective Communication Disorder majors must have a 3.0 grade point average.

One-half of the credits in the major must be completed at New Paltz.

SULLIVAN COURSES	EQUIVALENT NEW PALTZ COURSE
ENG 1301 Fundamentals of Speech	CMM 104 Public Speaking
<i>Liberal Arts major only:</i>	
FLA 1809 American Sign Language I	CMD 101 Elem. American Sign Lang. I
FLA 2809 American Sign Language II	CMD 102 Elem. American Sign lang. II
<i>Speech and Language Disabilities major only:</i>	
SBS 1502 Child Development and Guidance	PSY 343 Psychology of Infancy and Childhood
OR	
SBS 2502 Child Psychology	

Sullivan courses not listed above may be accepted in transfer by New Paltz as general elective credit toward the degree with the exception of those courses which are remedial/developmental in nature.

COMMUNICATION AND MEDIA

The Department of Communication and Media offer several major programs with special tracks within each: Communication Studies includes emphases in Interpersonal /Intercultural Communication, Organizational Communication, Public Communication and Public Relations.

The Journalism major offers students theoretical understanding and the practical skills necessary to succeed in today's news media (See the JOURNALISM section of this booklet).

The Electronic Media major may choose from one of two tracks: management or production. Management majors prepare in areas such as advertising, global media systems, law, research, and programming, for management positions across the various media. Majors in the Production track learn how to use the tools necessary to create mediated messages, but more importantly, they learn how the technology allows them to communicate effectively.

Students electing the ELECTRONIC MEDIA PRODUCTION SEQUENCE must complete a minimum of two production courses within the New Paltz program. See the New Paltz catalog for details.

One-half of the credits in the major must be completed at New Paltz.

SULLIVAN COURSES	EQUIVALENT NEW PALTZ COURSE
COMMUNICATION STUDIES	
ENG 1301 Fundamentals of Speech	CMM 104 Public Speaking
BUS 1302 Principles of Advertising	CMM 221 Introduction to Advertising
ELECTRONIC MEDIA	
COM 2100 Mass Media	CMM 101 Media and Society
COM 2200 Media Writing Techniques	CMM 319 Electronic Media Writing

COM 2300 Audio Production
COM 2400 Video Production
ENG 1301 Fundamentals of Speech
BUS 1302 Principles of Advertising
COM 1500 Intro to Broadcasting*
COM 2125 Mass Media Criticism*
COM 2600 Advanced Production*
COM 2405 Desktop/Digital Video Production*
COM 2410 TV Newscast Production*

CMM 320 Audio Production
CMM 340 Studio Video Production
CMM 104 Public Speaking
CMM 221 Introduction to Advertising
 No corresponding course*
 No corresponding course*
 No corresponding course*
 No corresponding course*
 No corresponding course*

**May be used as elective credit toward the New Paltz Electronic Media major where applicable.*

Sullivan courses not listed above may be accepted in transfer by New Paltz as general elective credit toward the degree with the exception of those courses which are remedial/developmental in nature.

COMPUTER SCIENCE

The Department of Computer Science at New Paltz offers a liberal arts major in Computer Science and the Math Department offers a major in Mathematics with a concentration in Computer Science.

Transfer students from a two-year degree program in Computer Science which includes several semesters of college-level mathematics (calculus or above) and at least three courses in Computer Science can usually complete the major in Computer Science in two years. See the New Paltz catalog for details.

One-half of the credits in the major must be completed at New Paltz.

SULLIVAN COURSES

EQUIVALENT NEW PALTZ COURSE

CPT 2216 Introduction to C++ and Object
 Oriented Programming
MAT 1301 Analytical Geometry and Calculus I
MAT 2301 Analytical Geometry and Calculus II

CPS 210 Computer Science I: Foundations
MAT 251 Calculus I
MAT 252 Calculus II

Select one science sequence:

SCI 1202 General Chemistry I

AND

SCI 1203 General Chemistry I Lab

SCI 2202 General Chemistry II

AND

SCI 2203 General Chemistry II Lab

OR

SCI 1302 Calculus Physics I - Mechanics

AND

SCI 1303 Calculus Physics I Lab

SCI 2302 Calculus Physics II

AND

SCI 2303 Calculus Physics II Lab

CHE 201 General Chemistry I

CHE 202 General Chemistry II

PHY 201 General Physics I

PHY 202 General Physics II

Sullivan courses not listed above may be accepted in transfer by New Paltz as general elective credit toward the degree with the exception of those courses which are remedial/developmental in nature.

ECONOMICS

New Paltz offers a B.A. and a B.S. in Economics which is designed to incorporate a liberal arts education with a strong background in economics. In addition to the core requirements of the Economics program, students have the option of concentrating in Business Economics, International Economics or they may choose a general Economics program. The Economics program requires 42-43 credits. A minimum of College Algebra is required in the Economics program. See the New Paltz catalog for details.

One-half of the credits in the major must be completed at New Paltz.

SULLIVAN COURSES

SBS 1401 Macro Economics
SBS 1402 Micro Economics

EQUIVALENT NEW PALTZ COURSE

ECO 207 Macroeconomics
ECO 206 Microeconomics

Sullivan courses not listed above may be accepted in transfer by New Paltz as general elective credit toward the degree with the exception of those courses which are remedial/developmental in nature.

EDUCATION

SUNY New Paltz offers undergraduate programs leading to certification in the following fields:

- *Early Childhood (B-2), Childhood (1-6) and Special/Childhood Education (1-6)
- * Adolescence (7-12)
- *Art (K-12) (See ART EDUCATION)
- *Speech and Hearing Handicapped (See COMMUNICATION DISORDERS section)

All of the above programs include intensive fieldwork in public schools and/or specialized institutions depending on the certification area selected.

EARLY CHILDHOOD (B-2) AND CHILDHOOD EDUCATION (1-6)

Students electing either childhood education certification programs must, in addition to, or as part of, the A.A. or A.S. degree, complete specific liberal arts coursework prerequisite to the curriculum, as well as choosing a liberal arts major.

Prerequisite liberal arts coursework includes:

- * **MAT 140** Math for Elementary School Teachers
- * **64240** Geometry: A Modern Introduction
- * **GEO 273** Basic Physical Geography
- * Two semesters of college level foreign language
- * **EDS 371** Child Psychology and Development
- * **EDS 340** Social and Philosophical Foundations of Education
- * **EED 370** Introduction to the Education of Diverse Populations in Early Childhood and Elementary School Settings

* A Liberal Arts major selected from:

Art History (30 credits)
Biology (31-35 credits)
Black Studies - History/Lit. (30 credits)
Earth Science (36 credits)
English (30 credits)
French (30-36 credits)

Geography (30 credits)
History (30 credits)
Mathematics (34 credits)
Political Science (36 credits)
Spanish (30-36 credits)

One half of the credits in the liberal art major/concentration must be completed at New Paltz. After meeting all criteria as listed above, as well as maintaining the grade point average required, students may enter the Professional Semester, and subsequently Student Teaching (See New Paltz catalog for details).

JOINTLY REGISTERED TEACHER EDUCATION PROGRAM

Students entering Sullivan County Community College may elect to be part of the Jointly Registered Teacher Education Program with SUNY New Paltz. This program is designed to facilitate the transfer of students preparing to become certified teachers in B-2 and 1-6 from Sullivan County Community College to SUNY New Paltz. The advantages of this program include the fact that transfer students can complete the childhood education program in four years (two at Sullivan and two at New Paltz) and are also eligible for scholarships designated for education majors.

Students admitted to the jointly registered program are simultaneously admitted to SUNY New Paltz. All JRTEP students must complete the A.S./A.A degree, achieve a 2.75 grade point average and interview with the School of Education advisor, to be admitted to SUNY New Paltz. Students must also maintain a grade point average of 2.75 their first semester at New Paltz to be admitted to the Professional Semester.

Students interested in this program must meet with the designated Sullivan Community College advisor before initial registration.

EARLY CHILDHOOD EDUCATION B-2

SULLIVAN COURSES

- MAT 1210** Mathematics for Elementary School Teachers I
- SBS 2502** Child Psychology
- OR**
- SBS 1502** Child Development & Guidance
- SBS 2921** Introduction to Early Childhood and Elementary Education

- ECE 2300** Infants and Toddlers

- ECE 1207** Observation and Participation in Early Childhood Education

EQUIVALENT NEW PALTZ COURSE

- MAT 140** Mathematics for Elementary School Teachers

- EDS 371** Child Psychology and Development
- EED 370** Introduction to the Education of Diverse Populations in Early Childhood and Elementary School Settings
- EED 411** Curriculum I: Infants and Toddlers
- EED 414** Developmentally Appropriate Practices for Children Birth - Second Grade

CHILDHOOD EDUCATION 1-6

SULLIVAN COURSES

- MAT 1210** Mathematics for Elementary School Teachers
- SBS 2502** Child Psychology
- OR**
- SBS 1502** Child Development & Guidance
- SBS 2921** Introduction to Early Childhood and Elementary Education

EQUIVALENT NEW PALTZ COURSE

- MAT 140** Mathematics for Elementary School Teachers I

- EDS 371** Child Psychology and Development
- EED 370** Introduction to the Education of Diverse Populations in Early Childhood and Elementary School Settings

NOTE:

1. All childhood (B-2/1-6) education students must complete one year of college-level study of a language other than English. See the FOREIGN LANGUAGE section of this booklet for Sullivan/New Paltz equivalencies. Sign Language I and II for AA/AS holders is acceptable in meeting this requirement.

2. For equivalent coursework in the various liberal arts majors see the appropriate sections of this booklet and the New Paltz catalog.

Students must successfully pass the Liberal Arts and Sciences test (LAST), the Assessment of Teaching Skills-Written (ATS-W) and the Content Specialty Test (CST) of the New York State Teacher Certification Examination in order to be eligible for initial certification. Additional testing in the Assessment of Teaching Skills-Performance (ATS-P) is required for professional certification. These regulations are changing based on the new standards. Check with your education advisor for NYSTCE requirements.

ADOLESCENCE EDUCATION (7-12)

The Adolescence Education department requires a 2.75 grade point average and achievement of a “B” or better in both Composition I and Composition II. Students seeking 7-12 certification must also major in one of the following disciplines:

Biology (65-72 credits)

Chemistry (56-59 credits)

Earth Science (59-65 credits)

English (42 credits)

French (36-48 credits)

Mathematics (47-48 credits)

Social Studies (45 credits)

Spanish (36-48 credits)

In addition to coursework required in the academic discipline (See appropriate sections of this booklet for equivalencies), one year of college level study of a language other than English, and a series of education courses is also required.

NOTE:

1. All adolescence (7-12) students must complete one year of college level study of a language other than English. See the FOREIGN LANGUAGE section of this booklet for Sullivan/New Paltz equivalencies. Sign Language I and II for AA/AS holders is acceptable in meeting this requirement.

2. For equivalent coursework in the various liberal arts majors see the appropriate sections of this booklet and the New Paltz catalog.

Students must successfully pass the Liberal Arts and Sciences test (LAST), the Assessment of Teaching Skills-Written (ATS-W) and the Content Specialty Test (CST) of the New York State Teacher Certification Examination in order to be eligible for initial certification. Additional testing in the Assessment of Teaching Skills-Performance (ATS-P) is required for professional certification. These regulations are changing based on the new standards. Check with your education advisor for NYSTCE requirements.

ELECTRICAL AND COMPUTER ENGINEERING

The Department offers comprehensive programs in Electrical Engineering and Computer Engineering. The Electrical and Computer Engineering programs are accredited by the Engineering Accreditation Commission (E.A.C.) of the Accreditation Board for Engineering and Technology (A.B.E.T.).

Electrical and Computer Engineering continue to be the growth programs in the field of engineering due to a rapidly changing technological society and expanding industrial needs. The program at SUNY New Paltz is designed to meet these needs generally, and more specifically the needs of the Mid-Hudson Valley. Engineering students graduate with a high level of technical competence combined with a liberal arts education that helps to develop managerial or research potential. Demonstrating its commitment to the liberal arts and sciences, the

university has designed a curriculum to insure that engineering students will have a solid background in the humanities and social sciences to complement their professional studies, and to provide them with the knowledge and skill necessary to adapt to a changing world.

A key feature of engineering at New Paltz is the close working relationship the university enjoys with local high technology industry. The interest and support of industry inspired the development of the program and now ensure that it continues to be relevant to expanding and changing industrial needs.

The flexible engineering curriculum is designed to serve full and part-time students, both traditional and non-traditional. The curriculum serves students new to the engineering field as well as those who have had some experience in technical areas.

Engineering students are educated in mathematics and the sciences under the direction of faculty from appropriate departments, while engineering courses are taught by engineering faculty. Students are prepared for research, development, and management positions or for further study of engineering at the graduate level in a research oriented atmosphere.

The Electrical Engineering and Computer Engineering curriculums consist of a humanities/social sciences component, a pre-engineering phase and upper division engineering coursework. It should be noted that because of A.B.E.T. accreditation, the engineering program requires a different, and more specific, liberal arts component than is required by other programs. For details of credits required in each component mentioned above, refer to the New Paltz catalog. See the New Paltz catalog for details.

One-half of the credits in the major must be completed at New Paltz.

SULLIVAN COURSES	EQUIVALENT NEW PALTZ COURSE
ENG 1001 Composition I	ENG 160 Freshman Composition I
ENG 2005 Composition II	ENG 180 Freshman Composition II
SCI 1202 General Chemistry I	CHE 201 General Chemistry I
AND	
SCI 1203 General Chemistry I Lab	CPS 210 Computer Science I: Foundations
CPT 2929 Introduction to C++ and Object Oriented Programming	
MAT 1301 Analytical Geometry and Calculus I	MAT 251 Calculus I
MAT 2301 Analytical Geometry and Calculus II	MAT 252 Calculus II
MAT 2302 Analytical Geometry and Calculus III	MAT 353 Calculus III
MAT 2401 Differential Equations	MAT 359 Ordinary Differential Equations
SCI 1302 Calculus Physics I - Mechanics	PHY 201 General Physics I
AND	
SCI 1303 Calculus Physics I Lab	PHY 202 General Physics II
SCI 2302 Calculus Physics II	
AND	PHY 315 Engineering Mechanics
SCI 2303 Calculus Physics II Lab	
ENS 2001 Engineering Statics	EGE 209 Circuits Laboratory
AND	
ENS 2002 Engineering Dynamics	EGC 208 Digital Logic Laboratory
EET 1104-1 DC Circuits	
AND	EGC 308 Microprocessor Laboratory
EET 1106-1 AC Circuits	
EET 1141 Digital I	MAT 381 Probability and Statistics I
EET 2214-1 Digital II/Microprocessors	EGE 322 Electronics Lab I
EET 2216-1 Statistical Process Control	EGE 323 Electronics Lab II
EET 1108-1 Analog Electronics I	
EET 2110-1 Analog Electronics II	

Sullivan courses not listed above may be accepted in transfer by New Paltz as general elective credit toward the degree with the exception of those courses which are remedial/developmental in nature.

ENGLISH

The Department of English offers programs designed to give students a knowledge of literary heritage and to develop skills as writers and critics. Within the English major at New Paltz, a student may select one of four options: general liberal arts, graduate preparatory, creative writing, or creative writing for the theater. In addition, students in the childhood (B-2/1-6), or adolescence (7-12) teacher certification programs may select an English major. See the New Paltz catalog for details.

One-half of the credits in the major must be completed at New Paltz.

SULLIVAN COURSES

EQUIVALENT NEW PALTZ COURSE

ENG 2117 American Literature I
ENG 2118 American Literature II

ENG 331 American Literature I
ENG 332 American Literature II

NOTE: Students who transfer both ENG 2117 and 2118 may need to complete a supplemental literature course at New Paltz to meet the minimum number of credits for the major plan.

Select three electives:

ENG 2001 Introduction to Literature

ENG 200 Analysis and Interpretation of Literature

ENG 2003 Advanced Composition

ENG 224 Expository Writing

ENG 2004 Creative Writing

ENG 345 Creative Writing

OR

ENG 2148 Special Topics: Advanced Poetry Workshop*

No corresponding course*

ENG 2007 South African Literature*

No corresponding course*

ENG 2030 The Comic Vision*

ENG 210 Great Books Western

ENG 2100 Masterpieces of Literature

ENG 307 The Novel*

ENG 2122 Modern Novel

No corresponding course*

ENG 2123 20th Century Literature*

No corresponding course*

ENG 2130 Modern Poetry*

No corresponding course*

ENG 2132 Introduction to Poetry*

ENG 310 Studies in Drama

ENG 2142 Modern Drama

No corresponding course*

ENG 2145 Literature of Toni Morrison*

No corresponding course*

ENG 2146 Shakespeare: A Study of Selected Works*

No corresponding course*

ENG 2147 Special Topics: Alternative Realities*

No corresponding course*

ENG 2150 The Short Story

ENG 308 Short Story

ENG 2926 African-American Literature in America*

No corresponding course*

**May be used as elective credit toward the New Paltz English major where applicable.*

EARLY CHILDHOOD (B-2)/CHILDHOOD (1-6) ENGLISH

One-half of the credits in the liberal art major/concentration must be completed at New Paltz.

SULLIVAN COURSES

EQUIVALENT NEW PALTZ COURSE

ENG 2117 American Literature I
OR

ENG 331 American Literature I

ENG 2118 American Literature II

ENG 332 American Literature II

Select two:

ENG 2001 Introduction to Literature

ENG 200 Analysis and Interpretation of Literature

ENG 2003 Advanced Composition

ENG 224 Expository Writing

ENG 2004 Creative Writing
OR
ENG 2148 Special Topics: Advanced Poetry Workshop*

ENG 345 Creative Writing

Select two electives:

ENG 2007 South African Literature*
ENG 2030 The Comic Vision*
ENG 2100 Masterpieces of Literature
ENG 2122 Modern Novel
ENG 2123 20th Century Literature*
ENG 2130 Modern Poetry*
ENG 2132 Introduction to Poetry*
ENG 2142 Modern Drama
ENG 2145 Literature of Toni Morrison*
ENG 2146 Shakespeare: A Study of Selected Works*
ENG 2147 Special Topics: Alternative Realities*
ENG 2150 The Short Story
ENG 2926 African-American Literature in America*

No corresponding course*
 No corresponding course*
ENG 210 Great Books Western
ENG 307 The Novel*
 No corresponding course*
 No corresponding course*
 No corresponding course*
ENG 310 Studies in Drama
 No corresponding course*
 No corresponding course*
 No corresponding course*
ENG 308 Short Story
 No corresponding course*

**May be used as elective course toward New Paltz English major/concentration where applicable.*

ADOLESCENCE (7-12) ENGLISH

One-half of the credits in the liberal arts major/concentration must be completed at New Paltz.

SULLIVAN COURSES

EQUIVALENT NEW PALTZ COURSE

ENG 2117 American Literature I
ENG 2118 American Literature II
ENG 2001 Introduction to Literature

ENG 2003 Advanced Composition

ENG 331 American Literature I
ENG 332 American Literature II
ENG 200 Analysis and Interpretation of Literature
ENG 224 Expository Writing

NOTE: Students who transfer both ENG 2117 and 2118 may need to complete a supplemental literature course at New Paltz to meet the minimum number of credits for the major plan.

Select three electives:

ENG 2004 Creative Writing
OR
ENG 2148 Special Topics: Advanced Poetry Workshop*
ENG 2007 South African Literature*
ENG 2030 The Comic Vision*
ENG 2100 Masterpieces of Literature
ENG 2122 Modern Novel
ENG 2123 20th Century Literature*
ENG 2130 Modern Poetry*
ENG 2132 Introduction to Poetry*
ENG 2142 Modern Drama
ENG 2145 Literature of Toni Morrison*
ENG 2146 Shakespeare: A Study of Selected Works*
ENG 2147 Special Topics: Alternative Realities*
ENG 2150 The Short Story
ENG 2926 African-American Literature in America*

ENG 345 Creative Writing

 No corresponding course*
 No corresponding course*
ENG 210 Great Books Western
ENG 307 The Novel*
 No corresponding course*
 No corresponding course*
 No corresponding course*
ENG 310 Studies in Drama
 No corresponding course*
 No corresponding course*
 No corresponding course*
ENG 308 Short Story
 No corresponding course*

**May be used as elective course toward New Paltz English major/concentration where applicable.*

Sullivan courses not listed above may be accepted in transfer by New Paltz as general elective credit toward the degree with the exception of those courses which are remedial/developmental in nature.

FOREIGN LANGUAGES

Sullivan students who have taken French or Spanish may continue that study at New Paltz, either as elective courses or as a major in one of those languages. Students in the childhood (B-2/1-6) education programs may select a French or Spanish major, while those in the adolescence (7-12) education program may select a French or Spanish major.

New Paltz also offers language instruction in Chinese, Hebrew, Italian, Japanese, Kiswahili, Latin, and Russian. Other languages, such as Arabic, Polish, Portuguese, Swedish, and Yiddish are offered under the auspices of the Weekend and Summer Language Immersion Programs.

New Paltz regularly offers overseas programs of varying lengths in China, Ecuador, France, Italy, Spain, Russia, and Germany, giving students an excellent opportunity to develop language skills and to learn directly about the target cultures. See New Paltz catalog for details.

NOTE: Students seeking certification in childhood education or adolescence education must complete one year of college level foreign language.

One-half of the credits in the major must be completed at New Paltz.

SULLIVAN COURSES

EQUIVALENT NEW PALTZ COURSE

FRENCH

HUM 1455 French Language and Culture I
HUM 2455 French Language and Culture II
HUM 2456 French Language and Culture III
HUM 2457 French Language and Culture IV

FRN 101 Elementary French I
FRN 102 Elementary French II
FRN 201 Intermediate French I
FRN 202 Intermediate French II

LATIN

HUM 1921 Latin I
HUM 1922 Latin II

LAT 101 Elementary Latin I
LAT 102 Elementary Latin II

SPANISH

HUM 1445 Spanish Language and Culture I
HUM 2445 Spanish Language and Culture II
HUM 2446 Spanish Language and Culture III
HUM 2447 Spanish Language and Culture IV

SPA 101 Elementary Spanish I
SPA 102 Elementary Spanish II
SPA 201 Intermediate Spanish I
SPA 202 Intermediate Spanish II

Sullivan courses not listed above may be accepted in transfer by New Paltz as general elective credit toward the degree with the exception of those courses which are remedial/developmental in nature.

GEOGRAPHY

The department offers a comprehensive liberal arts major to prepare students for graduate study in geography or for employment in fields actively seeking geographers. Students in the childhood (B-2/1-6) programs may select a geography major, while those in the adolescence (7-12) program may select geography courses as part of the social studies major in the education curriculum. Additionally, the department offers a standard minor in geography. See the New Paltz catalog for details.

One-half of the credits in the major must be completed at New Paltz.

SULLIVAN COURSES**EQUIVALENT NEW PALTZ COURSE**

SBS 1700 World Geography	}	GEO 240 World Geography
SCI 1018 Physical Geology		}
AND		
SCI 1019 Physical Geology Laboratory		MAT 241 Introductory Statistics
MAT 2501 Elementary Statistics		GEO 383 Introduction to GIS
GIS 1101 Introduction to Geographic Information Technology		No corresponding course*
GIS 1121 Raster GIS		GEO 483 GIS Applications
GIS 1122 Vector GIS		GEO 382 Remote Sensing
GIS 2221 Introduction to Remote Sensing		No corresponding course*
GIS 2222 GIS Customization		No corresponding course*
GIS 2501 GIS Project		

*May be used as elective course toward New Paltz Geography major where applicable.

Sullivan courses not listed above may be accepted in transfer by New Paltz as general elective credit toward the degree with the exception of those courses which are remedial/developmental in nature.

GEOLOGICAL SCIENCES

Students may pursue a liberal arts major in geology with an optional emphasis in environmental geoscience or environmental geology. In addition, students in the childhood (B-2/1-6) or adolescence (7-12) teacher certification programs may select a geology major as part of the education curriculum.

The department has excellent laboratory and equipment facilities, including a full array of petrographic microscopes, a petrographic thin section preparation facility, complete survey equipment for field geology studies, x-ray diffraction and fluorescence equipment, a microcomputer laboratory, and access to an electron microscope facility. Members of the department encourage capable students to make maximum use of equipment, both in class and in supervised independent research. The department also sponsors field study classes which are important to the study of geology. See New Paltz catalog for details.

One-half of the credits in the major must be completed at New Paltz.

SULLIVAN COURSES**EQUIVALENT NEW PALTZ COURSE**

SCI 1018 Physical Geology	}	GLG 220 Physical Geology
AND		
SCI 1019 Physical Geology Laboratory		
SCI 1202 General Chemistry I	}	CHE 201 General Chemistry I
AND		
SCI 1203 General Chemistry I Lab		
SCI 2202 General Chemistry II	}	CHE 202 General Chemistry II
AND		
SCI 2203 General Chemistry II Lab		
SCI 1302 Calculus Physics I - Mechanics	}	PHY 201 General Physics I
AND		
SCI 1303 Calculus Physics I Lab		
SCI 2302 Calculus Physics II	}	PHY 202 General Physics II
AND		
SCI 2303 Calculus Physics II Lab		
MAT 1301 Analytical Geometry and Calculus I		MAT 251 Calculus I
SBS 2905 Introduction to Geographic Information Systems		GEO 383 Introduction to GIS

Select one:

MAT 2501 Elementary Statistics

MAT 2301 Analytical Geometry and Calculus II

MAT 241 Introductory Statistics

MAT 252 Calculus II

EARLY CHILDHOOD (B-2)/CHILDHOOD (1-6) EARTH SCIENCE

One-half of the credits in the liberal art major/concentration must be completed at New Paltz.

SULLIVAN COURSES

EQUIVALENT NEW PALTZ COURSE

SCI 1028 Introduction to Astronomy	}	}	AST 201 Exploring the Solar System OR AST 202 Exploring the Universe
AND			
SCI 1029 Introduction to Astronomy Lab			
SCI 1202 General Chemistry I	}	}	CHE 201 General Chemistry I
AND			
SCI 1203 General Chemistry I Lab			
SCI 1018 Physical Geology	}	}	GLG 220 Physical Geology
AND			
SCI 1019 Physical Geology Laboratory			
SCI 1020 Introduction to Meteorology	}	}	GLG 120 Weather and Environment
AND			
SCI 1021 Introduction to Meteorology Lab			

ADOLESCENCE (7-12) EARTH SCIENCE

One-half of the credits in the liberal art major/concentration must be completed at New Paltz.

SULLIVAN COURSES

EQUIVALENT NEW PALTZ COURSE

SCI 1028 Introduction to Astronomy	}	}	AST 201 Exploring the Solar System OR AST 202 Exploring the Universe
AND			
SCI 1029 Introduction to Astronomy Lab			
SCI 1018 Physical Geology	}	}	GLG 220 Physical Geology
AND			
SCI 1019 Physical Geology Laboratory			
SCI 1020 Introduction to Meteorology	}	}	GLG 120 Weather and Environment
AND			
SCI 1021 Introduction to Meteorology Lab			
SCI 1124 Principles of Biology I	}	}	BIO 201 General Biology I
AND			
SCI 1125 Principles of Biology I Lab			
SCI 2152 Principles of Biology II	}	}	BIO 202 General Biology II
AND			
SCI 2153 Principles of Biology II Lab			
SCI 1202 General Chemistry I	}	}	CHE 201 General Chemistry I
AND			
SCI 1203 General Chemistry I Lab			
SCI 2202 General Chemistry II	}	}	CHE 202 General Chemistry II
AND			
SCI 2203 General Chemistry II Lab			
SCI 1302 Calculus Physics I - Mechanics	}	}	PHY 201 General Physics I
AND			
SCI 1303 Calculus Physics I Lab			
SCI 2302 Calculus Physics II	}	}	PHY 202 General Physics II
AND			
SCI 2303 Calculus Physics II Lab			

MAT 2501 Elementary Statistics

MAT 241 Introductory Statistics

OR

MAT 1301 Analytical Geometry and Calculus I

MAT 251 Calculus I

Sullivan courses not listed above may be accepted in transfer by New Paltz as general elective credit toward the degree with the exception of those courses which are remedial/developmental in nature.

HISTORY/SOCIAL STUDIES

SUNY New Paltz offers a liberal arts major in history. In addition, education students in the childhood (B-2/1-6) teacher certification programs may select a history major, and those in the adolescence education (7-12) program, may select a social studies major.

The liberal arts history major requires 33 credits of history coursework including an upper-division seminar. Courses must be selected from European and United States History as well as from regions and cultures outside of these areas. See the History section of the New Paltz catalog for details. The adolescence education (7-12) certification curriculum requires a social studies major which consists of selected coursework in economics, political science and geography, as well as in history. See the Adolescence Education section of the New Paltz catalog for details.

One-half of the credits in the major must be completed at New Paltz.

SULLIVAN COURSES

EQUIVALENT NEW PALTZ COURSE

SBS 1221 United States History I:
From Colonial Era to 1865

HIS 221 United States History to 1865

SBS 1222 United States History II:
From 1865 to Present

HIS 222 US History Since 1865

SBS 1252 Modern History of Latin America*

May be used to satisfy the
NON WESTERN category*.

Select one:

SBS 1016 World War II*

HIS 317 World war II*

SBS 1023 The Vietnam Experience*

No corresponding course*

SBS 1224 The History of the African-American*

No corresponding course*

SBS 1226 Special Topics: History of Women in America*

WOM 316 History of Women in
US to 1880*

SBS 1252 Modern History of Latin America*

HIS 278 Latin American History
Since 1825*

SBS 1261 History of the Holocaust

HIS 373 The Holocaust

SBS 1270 Development of the Modern Middle East*

HIS 343 History of Islam and the
Middle East*

SBS 1287 Introduction to East Asia*

HIS 230 History of East Asia*

SBS 1290 History of Sullivan County*

HIS 390 Special Topics*

**May be used as elective credit toward the New Paltz History major where applicable.*

EARLY CHILDHOOD (B-2)/CHILDHOOD (1-6) HISTORY

One-half of the credits in the liberal art major/concentration must be completed at New Paltz.

SULLIVAN COURSES

EQUIVALENT NEW PALTZ COURSE

SBS 1221 American History I

HIS 221 US History to 1865

SBS 1222 American History II

HIS 222 US History Since 1865

SBS 1290 History of Sullivan County*
SBS 1341 American Government

No corresponding course*
POL 216 American Government
and Politics

Select one:

SBS 1252 Modern History of Latin America*

May be used to satisfy the GENDER, RACE
AND ETHNICITY category*.

SBS 1261 History of the Holocaust

HIS 373 The Holocaust

Select one:

SBS 1270 Development of the Modern Middle East

HIS 343 History of Islam and the
Middle East

SBS 1287 Introduction to East Asia*

No corresponding course*

**May be used as elective credit toward the New Paltz History major where applicable.*

ADOLESCENCE (7-12) SOCIAL STUDIES

One-half of the credits in the liberal art major/concentration must be completed at New Paltz.

SULLIVAN COURSES

EQUIVALENT NEW PALTZ COURSE

SBS 1221 United States History I:
From Colonial Era to 1865

HIS 221 United States History to 1865

SBS 1222 United States History II:
From 1865 to Present

HIS 222 United States History Since 1865

SBS 1252 Modern History of Latin America

May be used to satisfy the
NON WESTERN category.

SBS 1261 History of the Holocaust

HIS 373 The Holocaust

SBS 1270 Development of the Modern Middle East

HIS 343 History of Islam and the
Middle East

SBS 1287 Introduction to East Asia*

No corresponding course*

SBS 1401 Macro Economics

ECO 207 Macroeconomics

SBS 1402 Micro Economics

ECO 206 Microeconomics

SBS 1341 American Government

POL 216 American Government
and Politics

**May be used as elective credit toward the New Paltz Social Studies major where applicable.*

Sullivan courses not listed above may be accepted in transfer by New Paltz as general elective credit toward the degree with the exception of those courses which are remedial/developmental in nature.

INTERNATIONAL RELATIONS

SUNY New Paltz is the only Liberal Arts and Sciences unit in the SUNY System to offer the International Relations major. The major and minor in International Relations offer students the opportunity to acquire an in-depth introduction to the field of international relations. The core disciplines of this field of study are Political Science, History and Economics. Courses are also drawn from the Departments of Anthropology, Black Studies, Geography, and Sociology and accepted for credit in the program. Students majoring in International Relations can, usually after further training at the graduate level, go on to occupations in the business world, government service and education. Since students will be working in a number of departments while at New Paltz, the International Relations major is also a good choice for those looking for a broadly-based field of study even if they will not be pursuing a career in the International area.

International Relations can be combined in creative ways with offerings of other major and minor programs. For example, a major in International Relations can be combined with minors in Business, Political Science, History, Economics or any of the other departments which offer courses in the program. Alternatively, students can minor in International Relations while majoring in one of the other departments. Such combinations will often enhance a student's record as he or she applies for employment after graduation or for admission to graduate programs. See the New Paltz catalog for details.

One-half of the credits in the major must be completed at New Paltz.

SULLIVAN COURSES

EQUIVALENT NEW PALTZ COURSE

Economics - International Relations major only:

SBS 1401 Macro Economics
SBS 1402 Micro Economics

ECO 207 Macroeconomics
ECO 206 Microeconomics

Sullivan courses not listed above may be accepted in transfer by New Paltz as general elective credit toward the degree with the exception of those courses which are remedial/developmental in nature.

JOURNALISM

The Journalism program at SUNY New Paltz, housed in the Department of Communication and Media, offers a course of study that students will absolutely need if they are to succeed in today's news media. At New Paltz, students will have the chance to obtain a bachelor's degree in journalism, a degree that is only available at two publicly funded universities in New York State.

Students will be trained in the essentials of journalism in order to prepare them for a professional internship. Students take a range of practical news writing and news gathering courses and combine them with theoretical classes that introduce the role of the mass media in America's democracy. Courses dealing with the history, ethics and law of the press are taught by a faculty of former reporters and editors who have not only worked in newsrooms, but who have also written books and articles about journalism.

In the practical journalism classes, students do all their writing in a computer laboratory that simulates a newsroom. For prospective editors, there is a desktop publishing system that teaches page design and graphics. See the New Paltz catalog for details.

One-half of the credits in the major must be completed at New Paltz.

SULLIVAN COURSES

EQUIVALENT NEW PALTZ COURSE

COM 2100 Mass Media
ENG 2003 Advanced Composition
ENG 2701 Journalism I
AND
ENG 2702 Journalism II

CMM 101 Media and Society
ENG 224 Expository Writing
JRN 230 Journalism I

Sullivan courses not listed above may be accepted in transfer by New Paltz as general elective credit toward the degree with the exception of those courses which are remedial/developmental in nature.

LATIN AMERICAN STUDIES

Although Sullivan does not offer Latin American Studies courses, a Latin American Studies major is available at New Paltz for those transfer students who wish to pursue one.

The major and minor in Latin American Studies are designed to provide students with a broad working knowledge of the region's history, geography, languages and cultures, as well as understanding of the diverse perspectives and value of its people. Students pursuing the major must take a required introductory course and a senior seminar, plus courses selected from a number of different departments, including Anthropology, History, Black Studies, Spanish, Geography, Political Science and Women's Studies. The major is designed to provide students with Spanish speaking skills sufficient for them to pursue some coursework in Latin American cultures and literature taught in Spanish. The Latin American Studies minor does not require proficiency in a foreign language. Students choose appropriate courses from at least three different departments and take a required introductory course.

Either a major or minor in Latin American Studies complements many other fields of study. As examples, a student majoring in International Relations, History, Business Administration, Spanish, or Geography can broaden his or her preparation for either graduate school or employment after graduation by completing a second major or minor in Latin American Studies. See New Paltz catalog for details.

One-half of the credits in the major must be completed at New Paltz.

SULLIVAN COURSES	EQUIVALENT NEW PALTZ COURSE
SBS 1252 Modern History of Latin America*	No corresponding course*
HUM 1445 Spanish Language and Culture I	SPA 101 Elementary Spanish I
HUM 2445 Spanish Language and Culture II	SPA 102 Elementary Spanish II
HUM 2446 Spanish Language and Culture III	SPA 201 Intermediate Spanish I
HUM 2447 Spanish Language and Culture IV	SPA 202 Intermediate Spanish II

**May be used as elective credit toward the New Paltz Latin American Studies major where applicable.*

Sullivan courses not listed above may be accepted in transfer by New Paltz as general elective credit toward the degree with the exception of those courses which are remedial/developmental in nature.

MATHEMATICS

The Mathematics major provides a strong theoretical background for graduate or industrial work in any area of mathematics. Three concentrations are available: pure mathematics, actuarial science and computer science. In addition, students in the Childhood (B-2/1-6) or Adolescence (7-12) teacher certification programs may select a mathematics major as part of the education curriculum.

Students develop a strong mathematical foundation applicable to many fields, the ability to think analytically and make sound judgements, and to organize, analyze and interpret numerical data. The department has adopted the Harvard calculus reform curriculum, which emphasizes that every topic be presented graphically, numerically and algebraically. The graphics calculator is an essential part of Calculus I and II, while Mathematica, a computer program utilized in performing mathematics, is used in more advanced courses. See the New Paltz catalog for details.

All prospective Mathematics majors must have completed up to Calculus I and be enrolled in Calculus II.

One-half of the credits in the major must be completed at New Paltz.

SULLIVAN COURSES	EQUIVALENT NEW PALTZ COURSE
MAT 1000 Basic Algebra	MAT 050 Basic Algebra
MAT 1003 College Mathematics II	
OR	
MAT 1205 Intermediate Algebra and Trigonometry	MAT 152 College Algebra
MAT 1206 Pre-Calculus	MAT 181 Pre-Calculus Mathematics
MAT 2501 Elementary Statistics	MAT 241 Introductory Statistics

LIBERAL ARTS MATHEMATICS MAJOR

One-half of the credits in the liberal art major/concentration must be completed at New Paltz.

SULLIVAN COURSES

EQUIVALENT NEW PALTZ COURSE

MAT 1301 Analytical Geometry and Calculus I
MAT 2301 Analytical Geometry and Calculus II
MAT 2302 Analytical Geometry and Calculus III
MAT 2203 Linear Algebra
MAT 2401 Differential Equations
CPT 2929 Introduction to C++ and Object Oriented Programming

MAT 251 Calculus I
MAT 252 Calculus II
MAT 353 Calculus III
MAT 362 Linear Algebra
MAT 359 Ordinary Differential Equations
CPS 210 Computer Science I: Foundations

EARLY CHILDHOOD (B-2)/CHILDHOOD (1-6) MATHEMATICS

One-half of the credits in the liberal art major/concentration must be completed at New Paltz.

SULLIVAN COURSES

EQUIVALENT NEW PALTZ COURSE

MAT 1210 Mathematics for Elementary School Teachers
MAT 2501 Elementary Statistics
MAT 1301 Analytical Geometry and Calculus I
MAT 2301 Analytical Geometry and Calculus II

MAT 140 Mathematics for Elementary School Teachers
MAT 241 Introductory Statistics
MAT 251 Calculus I
MAT 252 Calculus II

Select one:

CPT 2929 Introduction to C++ and Object Oriented Programming

CPS 210 Computer Science I: Foundations

CPT 1405 Computer Programming in MS Visual Basic

CPS 104 Visual Programming

Select one elective:

MAT 2302 Analytical Geometry and Calculus III
MAT 2203 Linear Algebra

MAT 353 Calculus III
MAT 362 Linear Algebra

ADOLESCENCE (7-12) MATHEMATICS

One-half of the credits in the liberal art major/concentration must be completed at New Paltz.

SULLIVAN COURSES

EQUIVALENT NEW PALTZ COURSE

MAT 1301 Analytical Geometry and Calculus I
MAT 2301 Analytical Geometry and Calculus II
MAT 2302 Analytical Geometry and Calculus III
MAT 2203 Linear Algebra
SCI 1302 Calculus Physics I - Mechanics
AND
SCI 1303 Calculus Physics I Lab
SCI 2302 Calculus Physics II
AND
SCI 2303 Calculus Physics II Lab

MAT 251 Calculus I
MAT 252 Calculus II
MAT 353 Calculus III
MAT 362 Linear Algebra
PHY 201 General Physics I
PHY 202 General Physics II

Select one:

CPT 2929 Introduction to C++ and Object Oriented Programming

CPT 1405 Computer Programming in MS Visual Basic

CPS 210 Computer Science I: Foundations

CPS 104 Visual Programming

Sullivan courses not listed above may be accepted in transfer by New Paltz as general elective credit toward the degree with the exception of those courses which are remedial/developmental in nature.

MUSIC

Programs in music are designed to develop awareness of the beauty and meaning of the art as practiced in the past and present. Flexibility is encouraged in the planning of individual programs, both for those who wish to major in music and for those who wish to acquaint themselves with this facet of our culture. Most music courses reflect an integrated approach to the study of music.

Music majors will choose a concentration in performance (Classical or Jazz), music history and literature, or music theory and composition. SUNY New Paltz is fully accredited by the National Association of Schools of Music and the American Music Therapy Association. See the New Paltz catalog for details.

Prospective Music majors must participate in an audition.

One-half of the credits in the major must be completed at New Paltz.

SULLIVAN COURSES

HUM 1204 Introduction to Jazz

HUM 1214 History of American Popular Music*

EQUIVALENT NEW PALTZ COURSE

MUS 160 History of Jazz

No corresponding course*

**May be used as elective credit toward the New Paltz Music major where applicable.*

Sullivan courses not listed above may be accepted in transfer by New Paltz as general elective credit toward the degree with the exception of those courses which are remedial/developmental in nature.

Placement Exams:

At the time of audition, all students take placement exams in theory, sight singing and ear training to determine their levels of proficiency. Students may choose to take placement exams in piano, voice and guitar in order to place into the advanced level or to waive a requirement.

PHILOSOPHY

The Department of Philosophy offers both a major leading to the B.A. degree and a minor. Our program is designed to acquaint students with the major divisions of philosophy (logic, theory of knowledge, metaphysics, ethics and political theory, and aesthetics), and with the principal historical and contemporary figures and schools.

Philosophy is inherently interdisciplinary, so many of our courses are connected with other disciplines and subjects such as the natural sciences, the social sciences, history, language, literature and the arts, religion, technology, business, and medicine. Philosophical study requires and enhances the ability to think and write critically and effectively, and is excellent preparation for graduate study in various professions, including medicine, law, government, business and journalism. See the New Paltz catalog for details.

One-half of the credits in the major must be completed at New Paltz.

SULLIVAN COURSES**EQUIVALENT NEW PALTZ COURSE****HUM 1300** Introduction to Philosophy***HUM 1304** Ethics**HUM 1310** Philosophical Thought***HUM 1320** Introduction to General Semantics***PHI 203** Introduction to Philosophy***PHI 304** Ethics**PHI 465** Philosophy of the Social Sciences***PHI 336** Philosophy of Language***May be used as elective credit toward the New Paltz Philosophy major where applicable.**Sullivan courses not listed above may be accepted in transfer by New Paltz as general elective credit toward the degree with the exception of those courses which are remedial/developmental in nature.***PHYSICS**

Physics is the study of the laws governing the natural universe. The great strength of a physics degree is its versatility; the problem solving skill of physicists is sought by a wide range of employers. There are career opportunities in university teaching/research, adolescence school teaching, government and industrial labs, medical technology, computer programming, management, and finance. Physics graduates also have a good base entry into the professional schools of law, medicine and dentistry, in addition to physics itself.

A dual degree program culmination in a B.S. in Physics and a B.S.E.E. in Electrical Engineering is also available. See the New Paltz catalog for details.

*One-half of the credits in the major must be completed at New Paltz.***SULLIVAN COURSES****EQUIVALENT NEW PALTZ COURSE****SCI 1302** Calculus Physics I - Mechanics**AND****SCI 1303** Calculus Physics I Lab**SCI 2302** Calculus Physics II**AND****SCI 2303** Calculus Physics II Lab**SCI 1202** General Chemistry I**AND****SCI 1203** General Chemistry I Lab**CPT 2929** Introduction to C++ and Object Oriented Programming**MAT 1301** Analytical Geometry and Calculus I**MAT 2301** Analytical Geometry and Calculus II**PHY 201** General Physics I**PHY 202** General Physics II**CHE 201** General Chemistry I**CPS 210** Computer Science I: Foundations**MAT 251** Calculus I**MAT 252** Calculus II**ADOLESCENCE (7-12) PHYSICS***One-half of the credits in the liberal art major/concentration must be completed at New Paltz.***SULLIVAN COURSES****EQUIVALENT NEW PALTZ COURSE****SCI 1302** Calculus Physics I - Mechanics**AND****SCI 1303** Calculus Physics I Lab**SCI 2302** Calculus Physics II**AND****SCI 2303** Calculus Physics II Lab**PHY 201** General Physics I**PHY 202** General Physics II

SCI 1202 General Chemistry I	}	—————	CHE 201 General Chemistry I
AND			
SCI 1203 General Chemistry I Lab	}	—————	CHE 202 General Chemistry II
AND			
SCI 2202 General Chemistry II			
AND	}	—————	CPS 210 Computer Science I: Foundations
SCI 2203 General Chemistry II Lab			
CPT 2929 Introduction to C++ and Object Oriented Programming			
MAT 1301 Analytical Geometry and Calculus I			MAT 251 Calculus I
MAT 2301 Analytical Geometry and Calculus II			MAT 252 Calculus II
MAT 2302 Analytical Geometry and Calculus III			MAT 353 Calculus III
MAT 2401 Differential Equations			MAT 359 Ordinary Differential Equations

Select one:

SCI 1018 Physical Geology	}	—————	GLG 220 Physical Geology
AND			
SCI 1019 Physical Geology Laboratory	}	—————	AST 201 Exploring the Solar System OR AST 202 Exploring the Universe
AND			
SCI 1028 Introduction to Astronomy			
AND	}	—————	BIO 201 General Biology I
SCI 1029 Introduction to Astronomy Lab			
SCI 1124 Principles of Biology I			
AND			
SCI 1125 Principles of Biology I Lab			

Sullivan courses not listed above may be accepted in transfer by New Paltz as general elective credit toward the degree with the exception of those courses which are remedial/developmental in nature.

POLITICAL SCIENCE

The department offers two separate liberal arts majors and three minors: majors in Political Science, and International Relations; minors in Political Science, International Relations, and Law and Politics. Education students in childhood (B-2/1-6) teacher certification programs may select a political science major as part of the education curriculum. Students majoring in Social Studies in the adolescence (7-12) teacher certification program may take political science courses as part of that major.

The Political Science program at New Paltz includes courses in American government and politics, comparative politics, political theory, international relations, and a variety of offerings in law and law-related fields. Students may participate annually for academic credit in a Model United Nations Program at Harvard University. The department also offers a full-semester internship program, with a wide variety of internship placements open to students in the New York State Legislature, public agencies of the Rockland, and New York City government. Internships are also available with the Legislative Gazette, which is the only weekly newspaper covering the N.Y.S. Legislature. See the New Paltz catalog for details.

One-half of the credits in the major must be completed at New Paltz.

SULLIVAN COURSES

EQUIVALENT NEW PALTZ COURSE

SBS 1322 Constitutional Law	POL 352 Constitutional Law: Civil Liberties
SBS 1341 American Government	POL 216 American Government and Politics
SBS 1350 Introduction to American Law	POL 350 Introduction to Law

Sullivan courses not listed above may be accepted in transfer by New Paltz as general elective credit toward the degree with the exception of those courses which are remedial/developmental in nature.

PRE-MEDICAL PROFESSIONS

SUNY New Paltz does not offer a pre-medical degree. Students who wish to enter such fields as medicine, dentistry, optometry, podiatry, osteopathy, or veterinary medicine need to pursue a strong college program, emphasizing mathematics and laboratory science. It should be understood that few colleges offer a true 'pre-med' program leading to a degree. What all colleges offer is the opportunity to prepare for admission to a health professional school by taking selected courses guided by a knowledgeable faculty advisor.

There is also no specific major required by health profession schools, however most students, therefore, opt for a major in the sciences since the majority of health profession school course requirements also fulfill portions of a biology, chemistry or physics major. It is important to note that entrance exams include substantial material dealing with the sciences.

Students may select the Liberal Arts and Sciences A.S. degree program at Sullivan and major in a related discipline at New Paltz upon transfer.

What coursework is necessary for the Pre-Med Professions?

All health profession schools require students to have a strong math/science background. The minimum course of study should be:

SULLIVAN COURSES	EQUIVALENT NEW PALTZ COURSE
SCI 1124 Principles of Biology I <i>AND</i> SCI 1125 Principles of Biology I Lab	BIO 201 General Biology I
SCI 2152 Principles of Biology II <i>AND</i> SCI 2153 Principles of Biology II Lab	
SCI 1202 General Chemistry I <i>AND</i> SCI 1203 General Chemistry I Lab	CHE 201 General Chemistry I
SCI 2202 General Chemistry II <i>AND</i> SCI 2203 General Chemistry II Lab	
SCI 2208 Organic Chemistry I <i>AND</i> SCI 2209 Organic Chemistry I Lab	CHE 318 Organic Chemistry I
SCI 2210 Organic Chemistry II <i>AND</i> SCI 2211 Organic Chemistry II Lab	
SCI 1302 Calculus Physics I - Mechanics <i>AND</i> SCI 1303 Calculus Physics I Lab	PHY 201 General Physics I
SCI 2302 Calculus Physics II <i>AND</i> SCI 2303 Calculus Physics II Lab	
MAT 2501 Elementary Statistics	MAT 241 Introductory Statistics
MAT 1301 Analytical Geometry and Calculus I	MAT 251 Calculus I
MAT 2301 Analytical Geometry and Calculus II	MAT 252 Calculus II

Many look for additional coursework in biology, chemistry or physics; consulting with the pre-med advisor will inform students of this information.

Where do New Paltz graduates go?

New Paltz graduates have found success in applying to professional schools; pre-medical students have been accepted at all four SUNY medical schools, as well as such schools as Albany Medical Center, Georgetown, Tufts, the University of Virginia, Mt. Sinai Medical Center, University of Buffalo, Rutgers University and others while pre-dental students have found equal success being accepted at such schools at NYU, Georgetown, University of Maryland, Northwestern and others. SUNY New Paltz also offers a pre-optometry/doctor of optometry program with the SUNY College of Optometry in NYC.

Advisement:

At both Sullivan Community College and SUNY New Paltz, a science faculty member serves as the Pre-Med Profession Advisor:

SULLIVAN

Division of Natural Sciences and Mathematics
Sullivan Community College
Loch Sheldrake, NY 12759-4002
(845) 434-5750

NEW PALTZ

Biology Department
SUNY New Paltz
I Hawk Drive
New Paltz, NY 12561-2499
(845) 257-3770

PSYCHOLOGY

New Paltz offers a general liberal arts Psychology major and also a specialized psychology major with an emphasis on Psychobiology. A minor in General Psychology, and Management and Organizational Psychology are also available.

The Psychobiology concentration requires courses in general biology and genetics, between three and six credits in research and several additional elective courses beyond the required psychology courses. See New Paltz catalog for details.

One-half of the credits in the major must be completed at New Paltz.

SULLIVAN COURSES

EQUIVALENT NEW PALTZ COURSE

Required:

SBS 1500 General Psychology
MAT 2501 Elementary Statistics

PSY 272 General Psychology
PSY 275 Psychological Statistics

Select three additional courses:

SBS 1502 Child Development and Guidance

OR

SBS 2502 Child Psychology

SBS 2505 Psychology of Exceptionality*

SBS 2506 Abnormal Psychology

SBS 2507 Behavior Modification:

SBS 2510 Developmental Psychology

SBS 2511 Psychology of Adjustment

SBS 2512 Forensic Psychology*

SBS 2521 Death & Dying: Psychological Perspective*

PSY 343 Psychology of Infancy
and Childhood

PSY 493 Selected Topics*

PSY 412 Abnormal Psychology

PSY 320 Behavior Modification

PSY 344 Psychology of Adolescence and
Adulthood

PSY 273 Psychology of Adjustment

PSY 493 Selected Topics*

PSY 493 Selected Topics*

**Only one "Selected Topics" will be accepted as elective credit toward the New Paltz Psychology major where applicable.*

Sullivan courses not listed above may be accepted in transfer by New Paltz as general elective credit toward the degree with the exception of those courses which are remedial/developmental in nature.

SOCIOLOGY

The liberal arts major in Sociology studies human society and group life. Students may select a major in Sociology or a major in Sociology with an emphasis in Direct Care. Both majors require the same four core courses, one of which is offered at Sullivan, SBS 1600 Introduction to Sociology, as well as additional elective courses. See New Paltz catalog for details.

One-half of the credits in the major must be completed at New Paltz.

SULLIVAN COURSES

EQUIVALENT NEW PALTZ COURSE

SBS 1600 Introduction to Sociology

SOC 100 Introduction to Sociology

Select three electives:

SBS 1602 Sociology of the Family

SOC 370 Sociology of Family

SBS 2601 Social Problems

SOC 376 Social Problems

SBS 2608 Introduction to Criminology

SOC 332 Criminology

ADA 1520 Drug Use and Abuse

SOC 425 Drugs in American Society

MHA 1510 Introduction to Human Services

SOC 350 Introduction to Human Services

Sullivan courses not listed above may be accepted in transfer by New Paltz as general elective credit toward the degree with the exception of those courses which are remedial/developmental in nature.

THEATER ARTS

Students majoring in Theater Arts may specialize in either Performance or Design/Technical. The department also offers a Theatre Arts minor.

Acting training in the Performance track is supported by classes in directing and musical theatre. The Design/Technical track offers unique programs with the International Alliance of Theatrical Stage Employees, internships with professional companies, and the opportunity for a B.F.A. degree in Scenography. See the New Paltz catalog for details.

Prospective Theatre Arts majors must participate in an audition.

One-half of the credits in the major must be completed at New Paltz.

SULLIVAN COURSES

EQUIVALENT NEW PALTZ COURSE

HUM 2700 Introduction to Acting

THE 231 Acting I

HUM 2703 Advanced Acting*

No corresponding course*

ENG 2142 Modern Drama

THE 324 World Drama II

**May be used as elective credit toward the New Paltz Theater Arts major where applicable.*

Sullivan courses not listed above may be accepted in transfer by New Paltz as general elective credit toward the degree with the exception of those courses which are remedial/developmental in nature.

WOMEN'S STUDIES

Women's Studies is an interdisciplinary academic program offering a Bachelor of Arts degree. The foundation of the program is the study of women, past and present, in various fields of inquiry. The courses examine the presuppositions of academic disciplines from a feminist, multicultural perspective. They explore aspects of women's social, cultural and political experience in the United States and throughout the world. Some courses

are offered through Women's Studies, and others are offered through other academic departments. An interdisciplinary course, Women: Images and Realities, provides the introduction to the program. There is a women's studies Practicum and a Senior Seminar for majors. See New Paltz catalog for details.

One-half of the credits in the major must be completed at New Paltz.

SULLIVAN COURSES

EQUIVALENT NEW PALTZ COURSE

SBS 1226 Special Topics: History of Women in America*

WOM 316 History of Women in US to 1880*

Sullivan courses not listed above may be accepted in transfer by New Paltz as general elective credit toward the degree with the exception of those courses which are remedial/developmental in nature.

DISCLAIMER

Notwithstanding anything contained in this guide, the State University of New York at New Paltz expressly reserves the right, whenever it deems advisable (1) to change or modify its schedule of tuition and fees, (2) withdraw, cancel, reschedule or modify any course, program of study, degree or any requirement or policy in connection with the foregoing, and (3) to change or modify any academic or other policy.

AFFIRMATIVE ACTION

SUNY New Paltz supports Affirmative Action and Equal Opportunity and does not discriminate against individuals or groups on the basis of race, sex, age, national origin, religion, disability, veteran status, marital status, or sexual orientation in education or employment, or in any of its policies or programs. All actions toward employees and students are based upon performance-related criteria. Further, SUNY New Paltz will not tolerate sexual harassment of employees or students.

Any person alleging discrimination should contact the Affirmative Action Office at 845-257-3293.

ADMISSIONS INFORMATION

For additional information concerning admissions, financial aid, or if you wish to obtain a copy of the New Paltz catalog, please write or telephone:

Office of Undergraduate Admissions
State University of New York at New Paltz
100 Hawk Drive
New Paltz, New York 12561-2499

(845) 257-3200

For additional information concerning admissions, financial aid, or if you wish to obtain a copy of the Sullivan County Community College catalog, please write or telephone:

Office of Admissions
Sullivan County Community College
112 College Road
Loch Sheldrake, New York 12759-5151

(845) 434-5750 ext.4287

STATE UNIVERSITY OF NEW YORK
NEW PALTZ

www.newpaltz.edu

©2009 SUNY New Paltz